

EXCEPT AS OTHERWISE PROVIDED BY CONTRACT, THIS DRAWING AND SPECIFICATIONS SHALL NOT BE REPRODUCED, COPIED OR USED AS THE BASIS FOR MANUFACTURE OR SALE OF MATTER DEPICTED HEREIN WITHOUT THE EXPRESSED WRITTEN PERMISSION OF THE CLAUDE LAVAL CORPORATION, OR ITS ASSIGNEES.

NOTES:

1. INLET & OUTLET ARE 12" GROOVED PIPE.
2. MAXIMUM PRESSURE: 150 psi (10.3 bar).
3. MAXIMUM TEMPERATURE: 180°F (82.2°C).
4. PRESSURE LOSS: 3-12 psid (.2-.8 bar) AT RATED FLOW.
5. RATED FLOW: 2650-4900 gpm (600-1115 m³/hr).
6. APPROXIMATE DRY WEIGHT: 3186 lbs (1445 kg).
7. FINISH: LAKOS BLUE (EXTERIOR ONLY).

| REVISION HISTORY | | | | |
|------------------|-----|-------------|------|----------|
| ZONE | REV | DESCRIPTION | DATE | APPROVED |

THIS DRAWING HAS BEEN GENERATED AND IS MAINTAINED BY A CAD SYSTEM. CHANGES SHALL ONLY BE INCORPORATED AS DIRECTED BY AN APPROVED ENGINEERING CHANGE ORDER (ECO). PAPER COPIES ARE UNCONTROLLED.

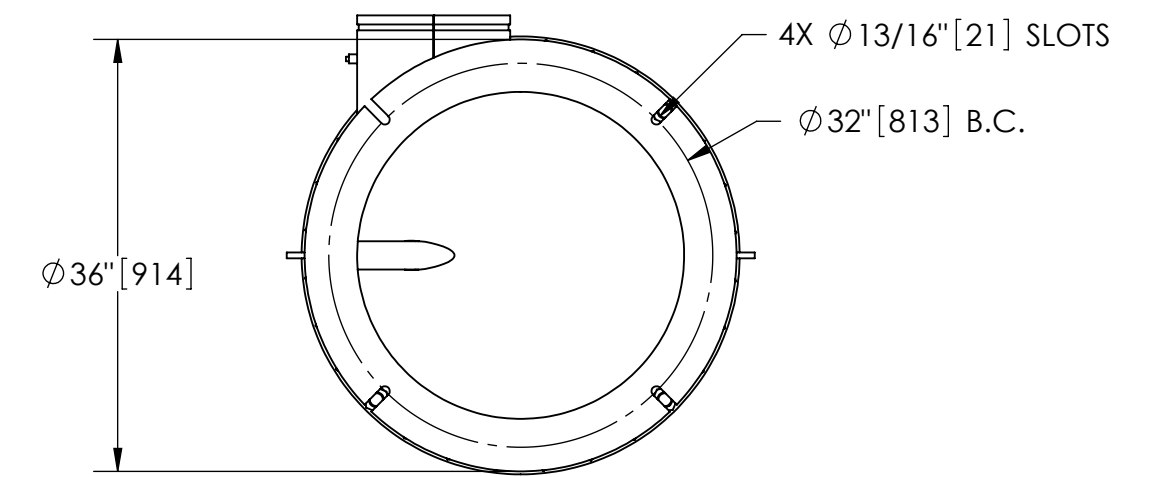
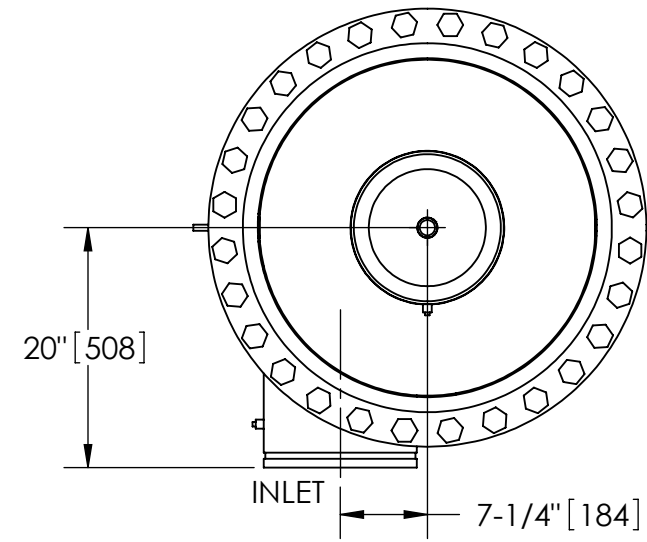

BOTTOM VIEW

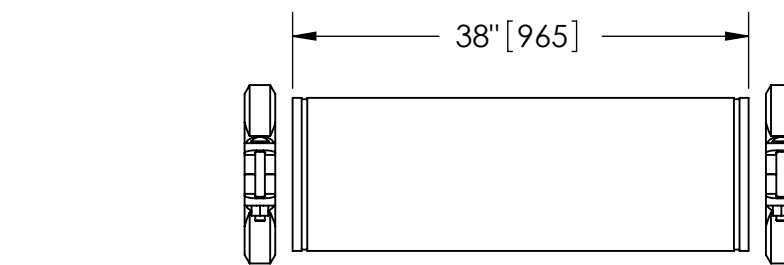

GROOVED SPOOL
MODEL GCS-1950/2650 (AVAILABLE SEPARATELY)
REQUIRED FOR REMOVAL OF TOP ASSEMBLY

SUBMITTAL DRAWING

This drawing is submitted for spatial consideration only. Do not pre-plumb to these dimensions.

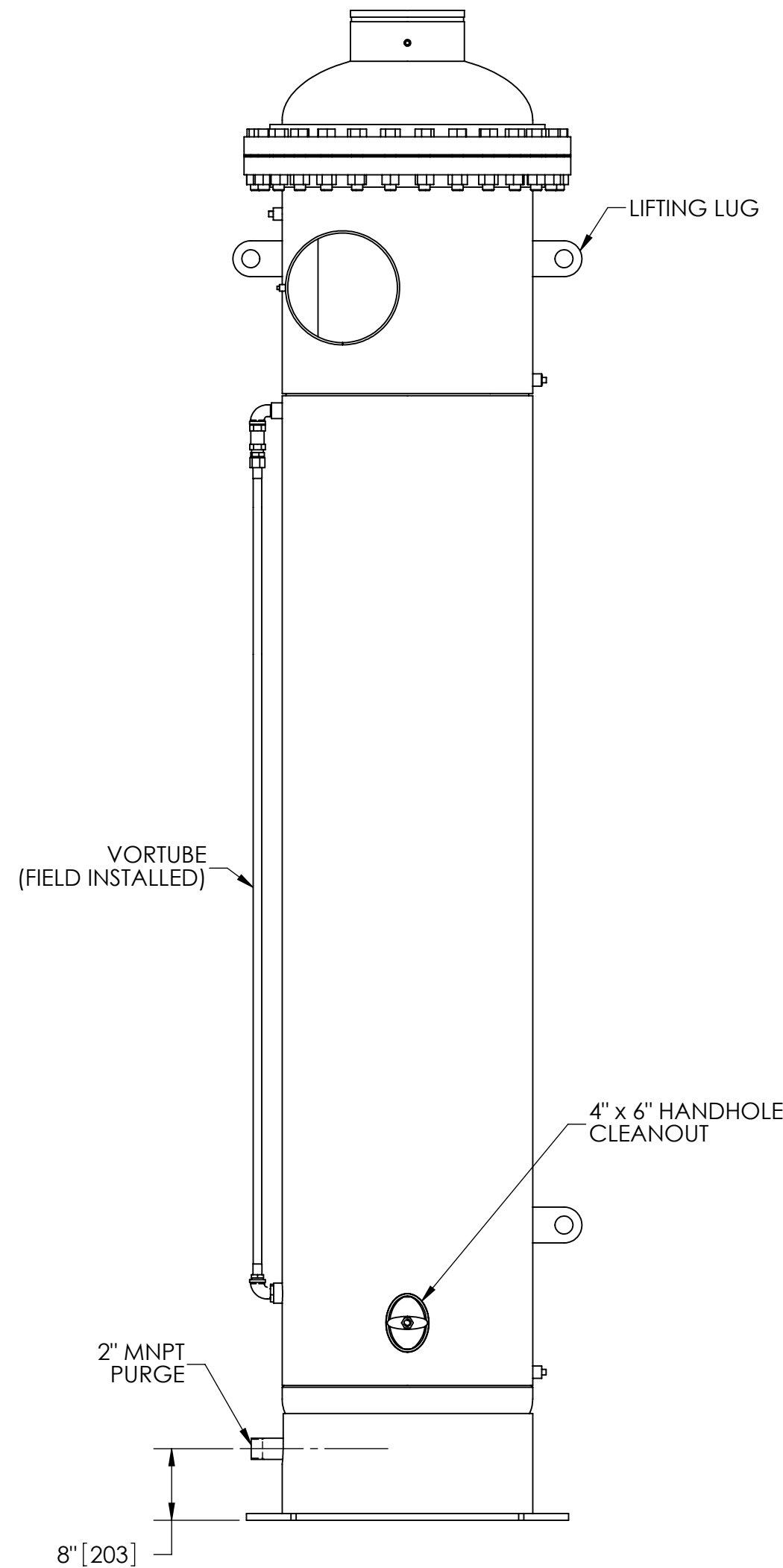
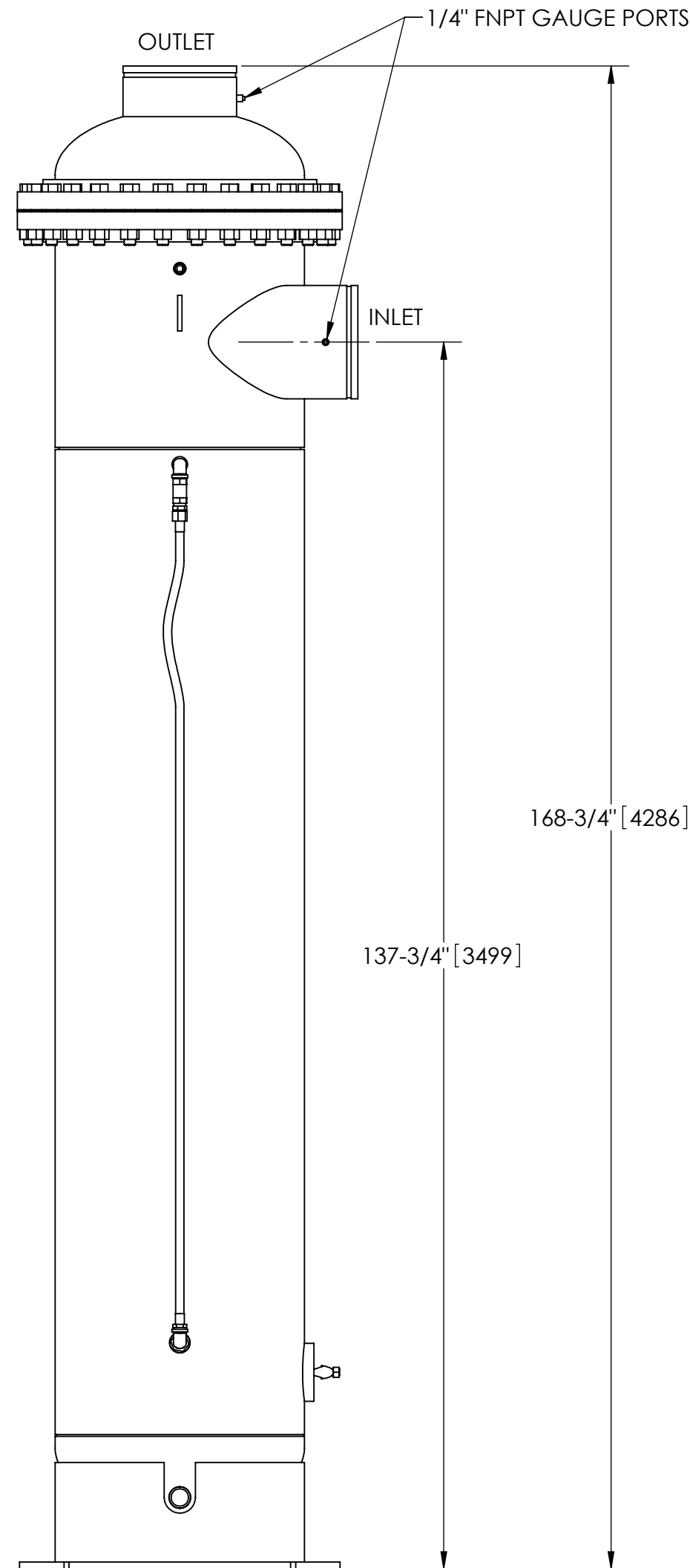

| | | | | | | | |
|---|--------------------------------|------------------------------------|------|---|---|---------------------------|-------------------------------|
| UNLESS OTHERWISE SPECIFIED: DIMENSIONS ARE IN: INCHES (mm) TOLERANCES ARE: FRACTIONS .XX ± .01 ANGLES ± 1/4° ± 1" .XXX ± .005 .XXX ± .0005 | | ENGINEERED FOR: STANDARD | | CLAUDE LAVAL CORP. FRESNO, CALIFORNIA 93727 WWW.LAKOS.COM | | LAVAL UNDERGROUND SURVEYS | |
| DO NOT SCALE DRAWING | | APPROVALS | DATE | TITLE | | | |
| MATERIAL | CLASS P-1 MILD CARBON STEEL | DRAWN | DLW | 10/16/07 | JPX-2650-V, SEPERATOR, 2650-4900 gpm, CARBON STEEL | | |
| FINISH | LAKOS BLUE | ENGR | JB | 12/19/07 | SIZE | MODEL NO. | DWG NO. |
| | | WORK ORDER | | | C | | 115254 |
| | | | | | SCALE | 1:16 | EST. WT. 3186 lb SHEET 1 OF 1 |

DWG NO.

115254

SHT

REV

G

A