

EXCEPT AS OTHERWISE PROVIDED BY CONTRACT, THIS DRAWING AND SPECIFICATIONS SHALL NOT BE REPRODUCED, COPIED OR USED AS THE BASIS FOR MANUFACTURE OR SALE OF MATTER DEPICTED HEREIN WITHOUT THE EXPRESSED WRITTEN PERMISSION OF THE CLAUDE LAVAL CORPORATION, OR ITS ASSIGNEES.

THIS DRAWING HAS BEEN GENERATED AND IS MAINTAINED BY A CAD SYSTEM. CHANGES SHALL ONLY BE INCORPORATED AS DIRECTED BY AN APPROVED ENGINEERING CHANGE ORDER (ECO). PAPER COPIES ARE UNCONTROLLED.

REVISIONS				
ECN	REV.	DESCRIPTION	DATE	APPROVED

**NOTES:**

1. INLET IS 8" PIPE (125# ANSI FLANGED).
2. OUTLET IS 6" PIPE (GROOVED).
3. PURGE OUTLET IS 1-1/2" PIPE.
4. MAXIMUM PRESSURE: 150 psi (10.3 bar).
5. MAXIMUM TEMPERATURE: 100°F (37.8°C).
6. SPECIFIED FLOWRATE OF 825 gpm (187 m³/hr).
7. FINISH: AS ASSEMBLED.
8. POWER REQUIREMENT: 460V, 3PH, 60Hz.
9. NEMA 4X MOTOR STARTER ENCLOSURE WITH SAFETY DISCONNECT AND H.O.A. SWITCH.
10. APPROXIMATE DRY WEIGHT: 2755 lbs (1250 kg).
11. INLET/OUTLET VALVE KIT, MODEL TCV-0825 RECOMMENDED.
12. MINIMUM PIPE FROM TOWER BASIN TO JC SYSTEM IS 8" PIPE.
13. FLOODED SUCTION REQUIRED.
14. LIFTING LUGS NOT SUPPLIED.

**COMPONENT LIST:**

- ① ELECTRICAL CONTROL BOX 460V 60Hz W/120V TRANSFORMER WITH RUN LIGHTS & BAG FULL LIGHT.
- ② SEPARATOR: JPX-0450-L.
- ③ PUMP: 30 HP CENTRIFUGAL, 1800 rpm, 460V, 60Hz, PREMIUM EFFICIENCY.
- ④ INLET/OUTLET PRESSURE GAUGES: 0-100 psi, GLYCERIN-FILLED.
- ⑤ PURGE EQUIPMENT: SRV-816.
- ⑥ DIFFERENTIAL PRESSURE INDICATOR WITH DRY CONTACT-MODEL DHE-15-S.
- ⑦ BASKET STRAINER.

**SUBMITTAL DRAWING**

This drawing is submitted for spatial consideration only. Do not pre-plumb to these dimensions.

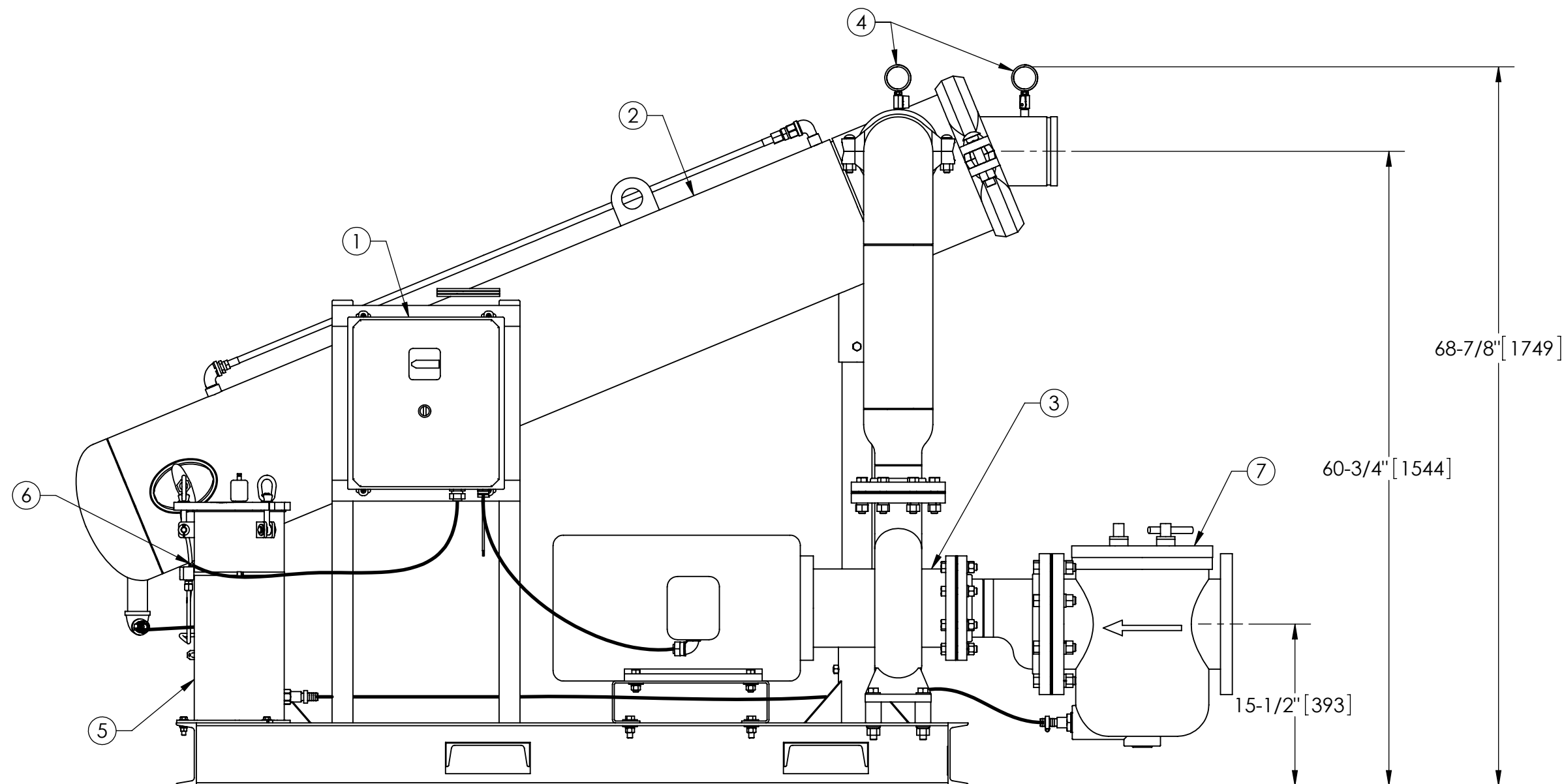
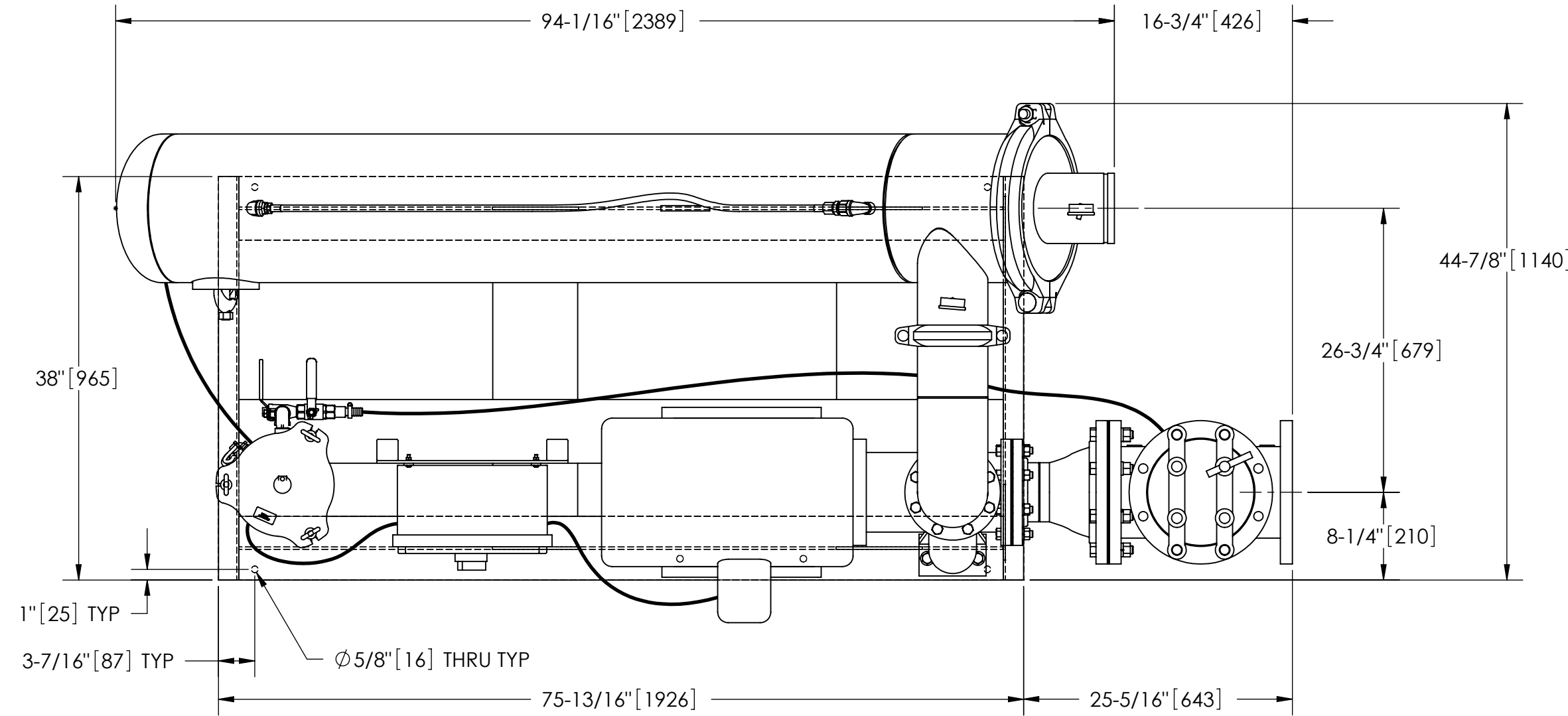

UNLESS OTHERWISE SPECIFIED: DIMENSIONS ARE IN: INCHES (mm) TOLERANCES ARE: FRACTIONS    DECIMALS    ANGLES ± 1"            .XX ± .01            ± 1/4° .XXX ± .005 .XXXX ± .0005		ENGINEERED FOR: <b>STANDARD</b>		CLAUDE LAVAL CORP. FRESNO, CALIFORNIA 93727 WWW.LAKOS.COM		LAVAL UNDERGROUND SURVEYS	
DO NOT SCALE DRAWING		APPROVALS	DATE	TITLE			
MATERIAL		DRAWN	3/28/11	JCX-0825-SRV/L, JC SYSTEM			
FINISH		ENGR	3/28/11	SWEEPER JPX-0450-L, 460V 60HZ DELUXE			
AS ASSEMBLED		MFG	-	SIZE	MODEL NO.	DWG NO.	REV.
		WORK ORDER	QTY.	C		132602	01
				SCALE	1:12	EST. WT.	2755 lb
						SHEET	1 OF 1

DWG NO.

132602

SHT

REV. 01

A