

EXCEPT AS OTHERWISE PROVIDED BY CONTRACT, THIS DRAWING AND SPECIFICATIONS SHALL NOT BE REPRODUCED, COPIED OR USED AS THE BASIS FOR MANUFACTURE OR SALE OF MATTER DEPICTED HEREIN WITHOUT THE EXPRESSED WRITTEN PERMISSION OF THE LAKOS CORPORATION, OR ITS ASSIGNEES.

REVISION HISTORY				
ZONE	REV	DESCRIPTION	DATE	APPROVED
	01	RELEASED FOR SUBMITTAL	3/3/21	TPF

NOTES:

1. INLET IS 8" FLANGED (125# ANSI FLANGED).
2. OUTLET IS 6" PIPE (150# ANSI FLANGED).
3. PURGE OUTLET IS 1-1/2" PIPE.
4. MAXIMUM PRESSURE: 150 psi (10.3 bar).
5. MAXIMUM FLUID OPERATING TEMPERATURE: 100°F (37.8°C).
6. SPECIFIED FLOW RATE: 1110 gpm (252 m³/hr).
7. FINISH: AS ASSEMBLED.
8. POWER REQUIREMENT: 3/60/460V.
9. NEMA 4X MOTOR STARTER ENCLOSURE WITH SAFETY DISCONNECT AND H.O.A. SWITCH.
10. APPROXIMATE DRY WEIGHT: 2917 lbs (1323 kgs).
11. INLET/OUTLET VALVE KIT RECOMMENDED: SEE FACTORY.
12. MINIMUM PIPE FROM TOWER BASIN TO JC SYSTEM IS 8" PIPE.
13. FLOODED SUCTION REQUIRED.

COMPONENT LIST:

- ① ELECTRICAL CONTROL BOX 3/60/460V W/120V TRANSFORMER.
- ② SEPARATOR: eJPX-0560-L.
- ③ PUMP: 25 HP CENTRIFUGAL, 1750 rpm, 3/60/460V.
- ④ INLET/OUTLET PRESSURE GAUGES: 0-160 psi, GLYCERIN-FILLED.
- ⑤ PURGE EQUIPMENT: EFS-15-120V.
- ⑥ STRAINER SUCTION DIFFUSER. (DIFFUSER SUPPORT WILL NOT BE SUPPLIED BY LAKOS)

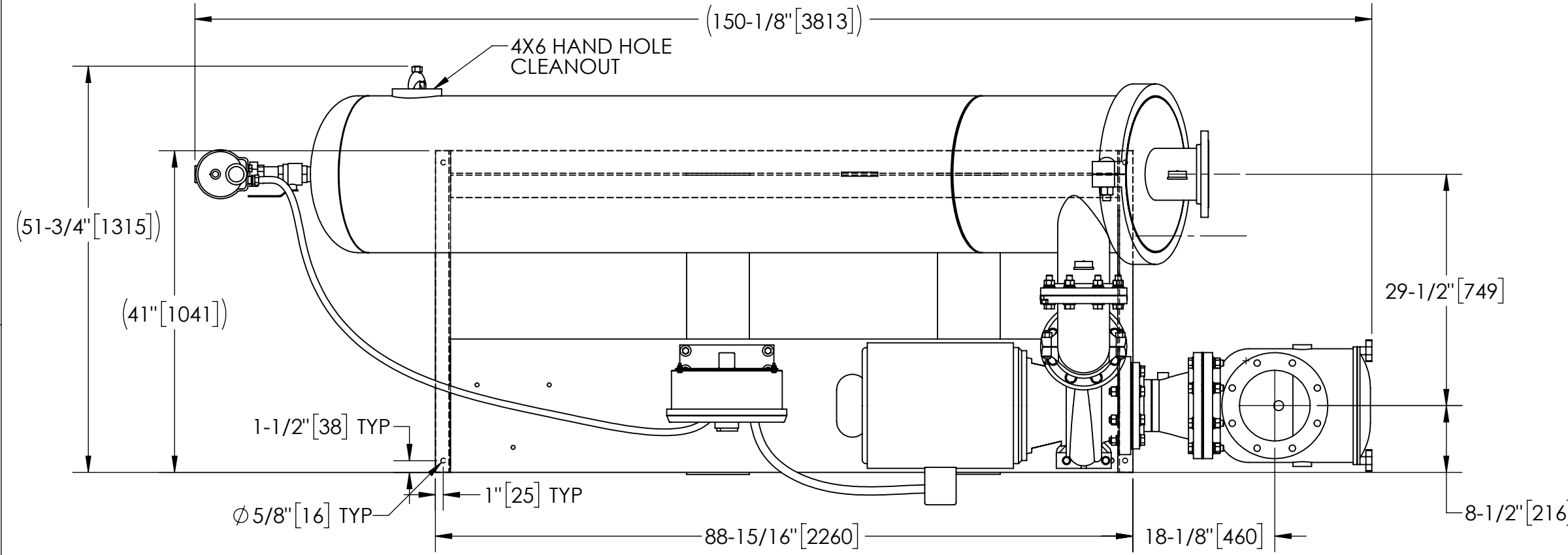

TOP VIEW

SUBMITTAL DRAWING

This drawing is submitted for spatial consideration only. Do not pre-plumb to these dimensions.

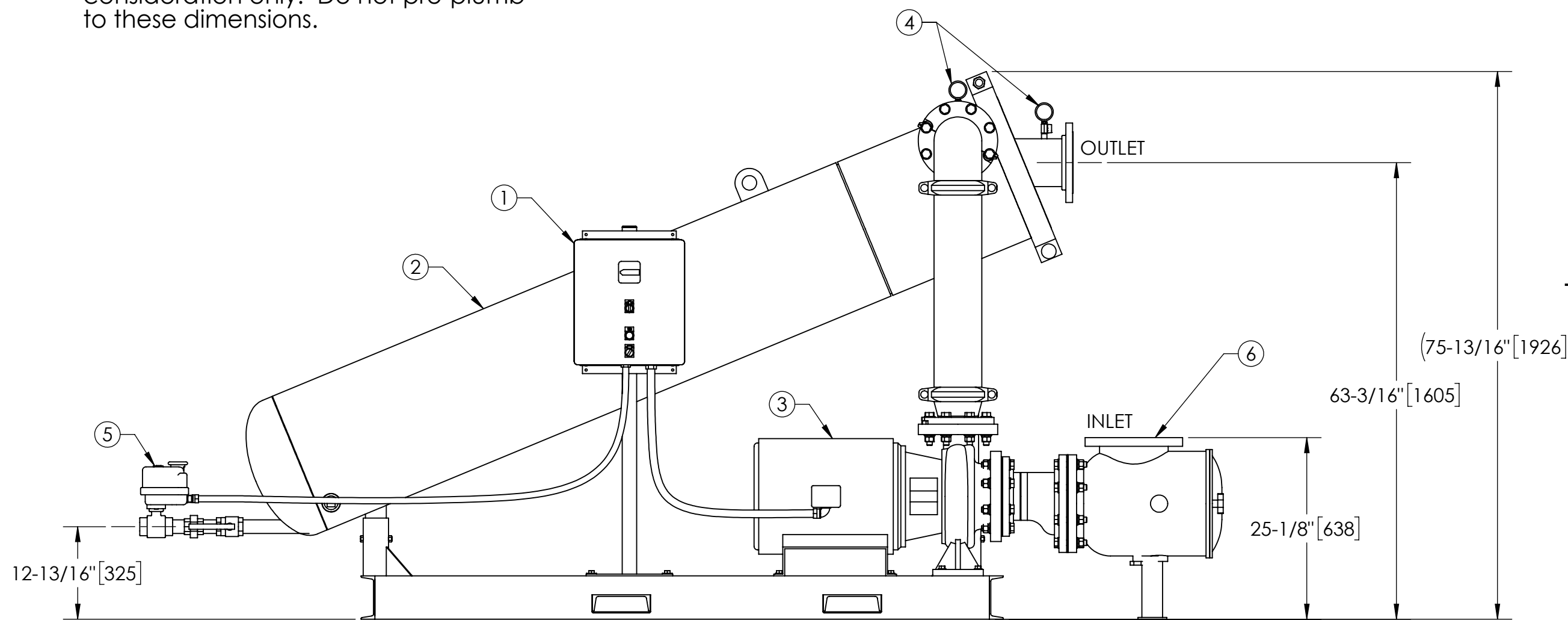

FRONT VIEW

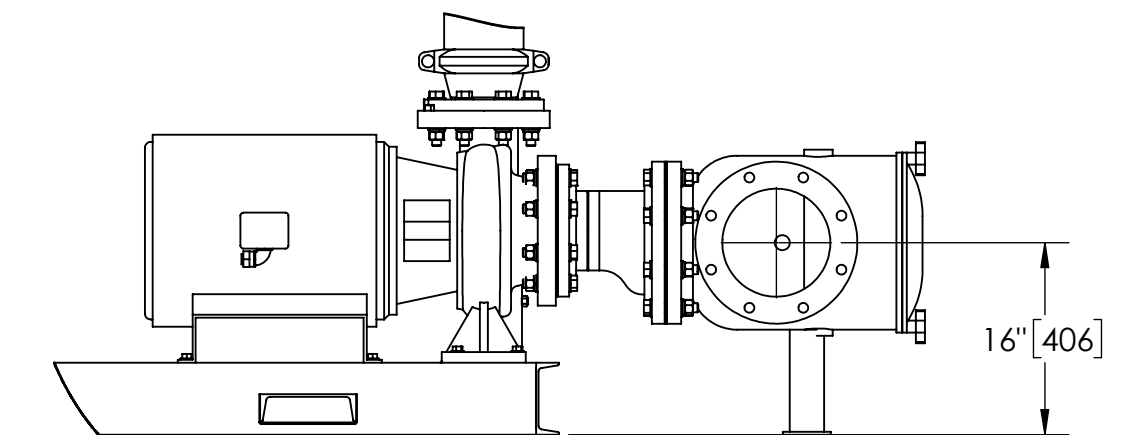

FRONT VIEW ROTATED STRAINER (OPTIONAL)

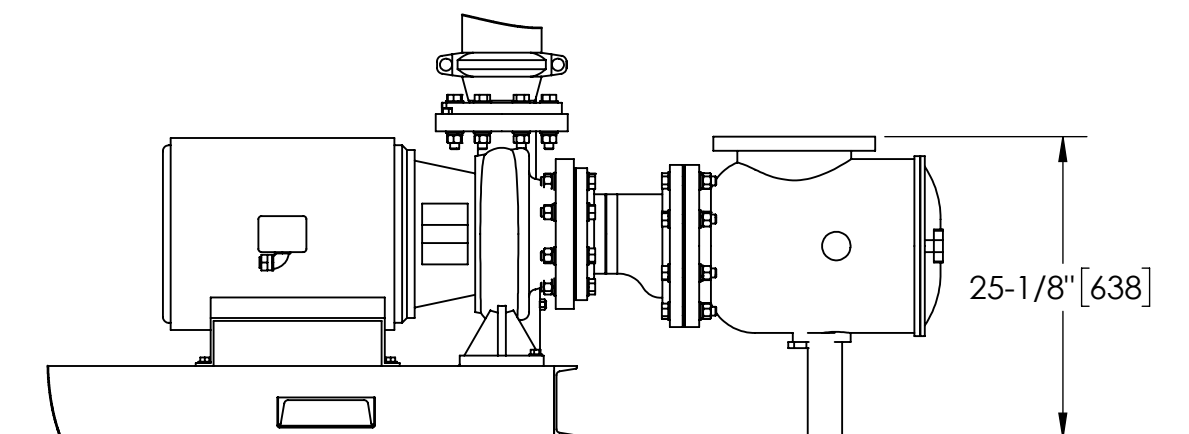

FRONT VIEW PUMP & STRAINER

THIS DRAWING HAS BEEN GENERATED AND IS MAINTAINED BY A CAD SYSTEM. CHANGES SHALL ONLY BE INCORPORATED AS DIRECTED BY AN APPROVED ENGINEERING CHANGE ORDER (ECO). PAPER COPIES ARE UNCONTROLLED.

UNLESS OTHERWISE SPECIFIED: DIMENSIONS ARE IN: INCHES (mm) TOLERANCES ARE: FRACTIONS DECIMALS ANGLES ± 1" .XX ± .01 ± 1/4" XXX ± .005 XXXX ± .0005		ENGINEERED FOR: STANDARD			
DO NOT SCALE DRAWING		APPROVALS	DATE	TITLE	
MATERIAL PER LAKOS SPEC		ENGR	-	eJBX-1110-EFS, JC SYSTEM	
FINISH AS ASSEMBLED		REVIEW	-	HI EFF SIDESTRM eJPX-0560, 3/60/460V	
		WORK ORDER	QTY.	SIZE C	MODEL NO.
				SCALE 1:16	DWG NO. 185154
				EST. WT. 2917 lb	REV. 01
				SHEET 1 OF 1	

DWG. NO. 185154  
SHEET 1  
REV. 01