

EXCEPT AS OTHERWISE PROVIDED BY CONTRACT, THIS DRAWING AND SPECIFICATIONS SHALL NOT BE REPRODUCED, COPIED OR USED AS THE BASIS FOR MANUFACTURE OR SALE OF MATTER DEPICTED HEREIN WITHOUT THE EXPRESSED WRITTEN PERMISSION OF THE LAKOS CORPORATION, OR ITS ASSIGNEES.

THIS DRAWING HAS BEEN GENERATED AND IS MAINTAINED BY A CAD SYSTEM. CHANGES SHALL ONLY BE INCORPORATED AS DIRECTED BY AN APPROVED ENGINEERING CHANGE ORDER (ECO). PAPER COPIES ARE UNCONTROLLED.

| REVISION HISTORY |     |                        |         |          |
|------------------|-----|------------------------|---------|----------|
| ZONE             | REV | DESCRIPTION            | DATE    | APPROVED |
|                  | 01  | RELEASED FOR SUBMITTAL | 2/25/21 | TPF      |

NOTES:

1. INLET IS 6" PIPE (125# ANSI FLANGED).
2. OUTLET IS 4" PIPE (150# ANSI FLANGED).
3. PURGE OUTLET IS 1-1/2" PIPE.
4. MAXIMUM PRESSURE: 150 psi (10.3 bar).
5. MAXIMUM FLUID OPERATING TEMPERATURE: 100°F (37.8°C).
6. SPECIFIED FLOW RATES:  
BASIN SWEEPING- 410 gpm (93 m³/hr).  
SIDE STREAM & CLOSED LOOP- 490 gpm (111 m³/hr).
7. FINISH: AS ASSEMBLED.
8. POWER REQUIREMENT: 3/60/460V.
9. NEMA 4X MOTOR STARTER ENCLOSURE WITH SAFETY DISCONNECT AND H.O.A. SWITCH.
10. APPROXIMATE DRY WEIGHT: 1322 lbs (594 kg).
11. INLET/OUTLET VALVE KIT RECOMMENDED: SEE FACTORY.
12. MINIMUM PIPE FROM TOWER BASIN TO JC SYSTEM IS 6" PIPE.
13. FLOODED SUCTION REQUIRED.

COMPONENT LIST:

- ① ELECTRICAL CONTROL BOX 3/60/460V W/120V TRANSFORMER.
- ② SEPARATOR: eJPX-0250-V.
- ③ PUMP: 10 HP CENTRIFUGAL, 1770 rpm, 3/60/460V.
- ④ INLET/OUTLET PRESSURE GAUGES: 0-160 psi, GLYCERIN-FILLED.
- ⑤ PURGE EQUIPMENT: EFS-15-120V.
- ⑥ STRAINER, SUCTION DIFFUSER.

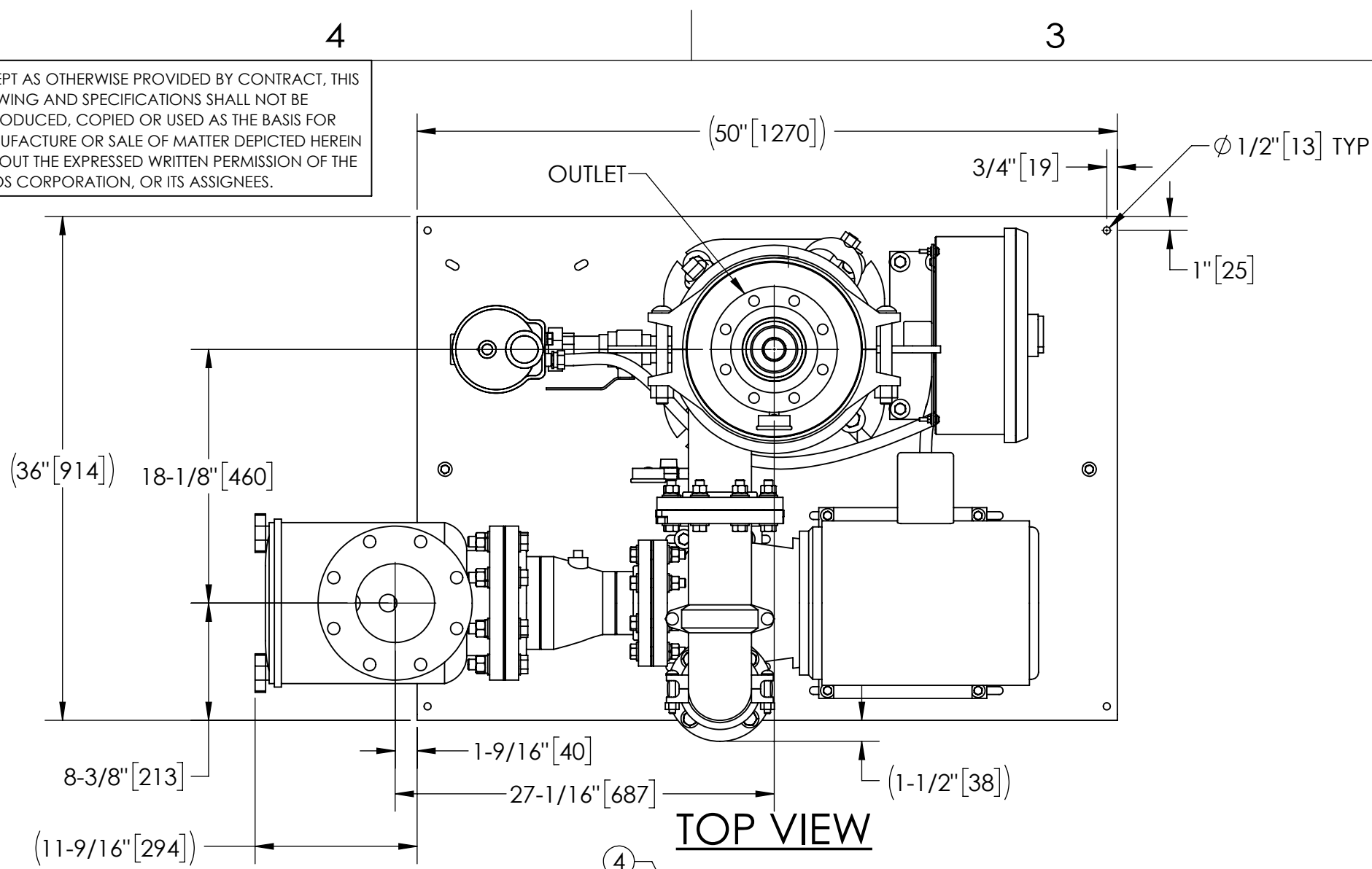

TOP VIEW

SUBMITTAL DRAWING

This drawing is submitted for spatial consideration only. Do not pre-plumb to these dimensions.

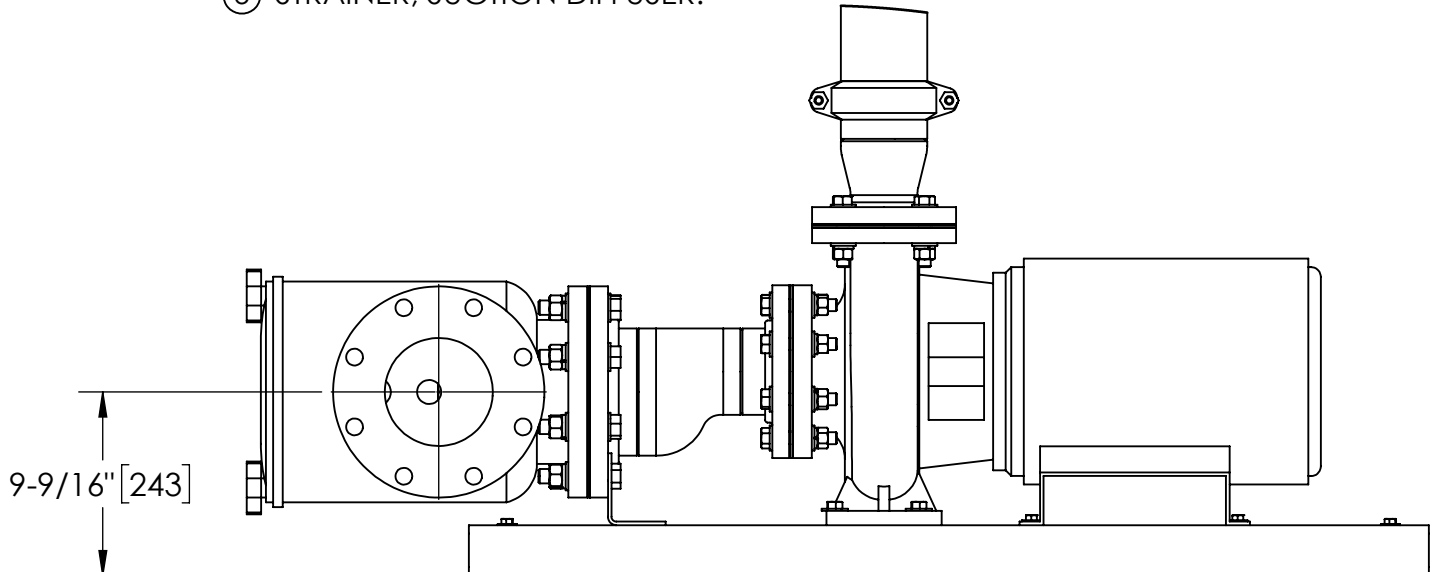

FRONT VIEW ROTATED STRAINER (OPTIONAL)

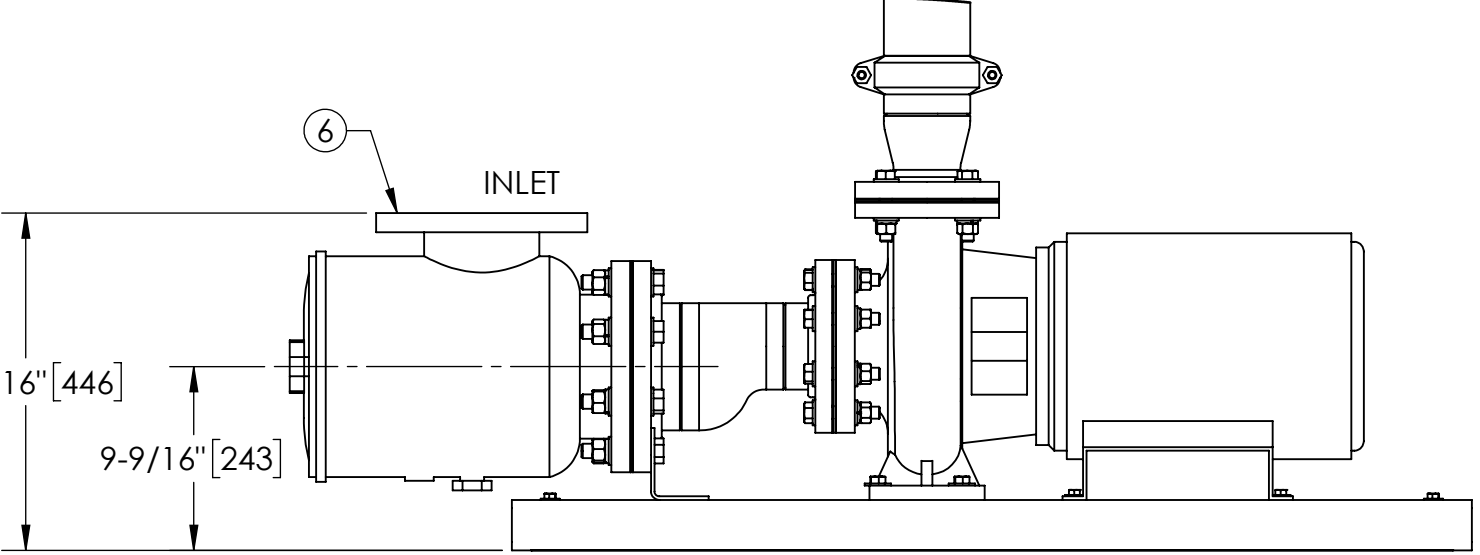

FRONT VIEW PUMP & STRAINER

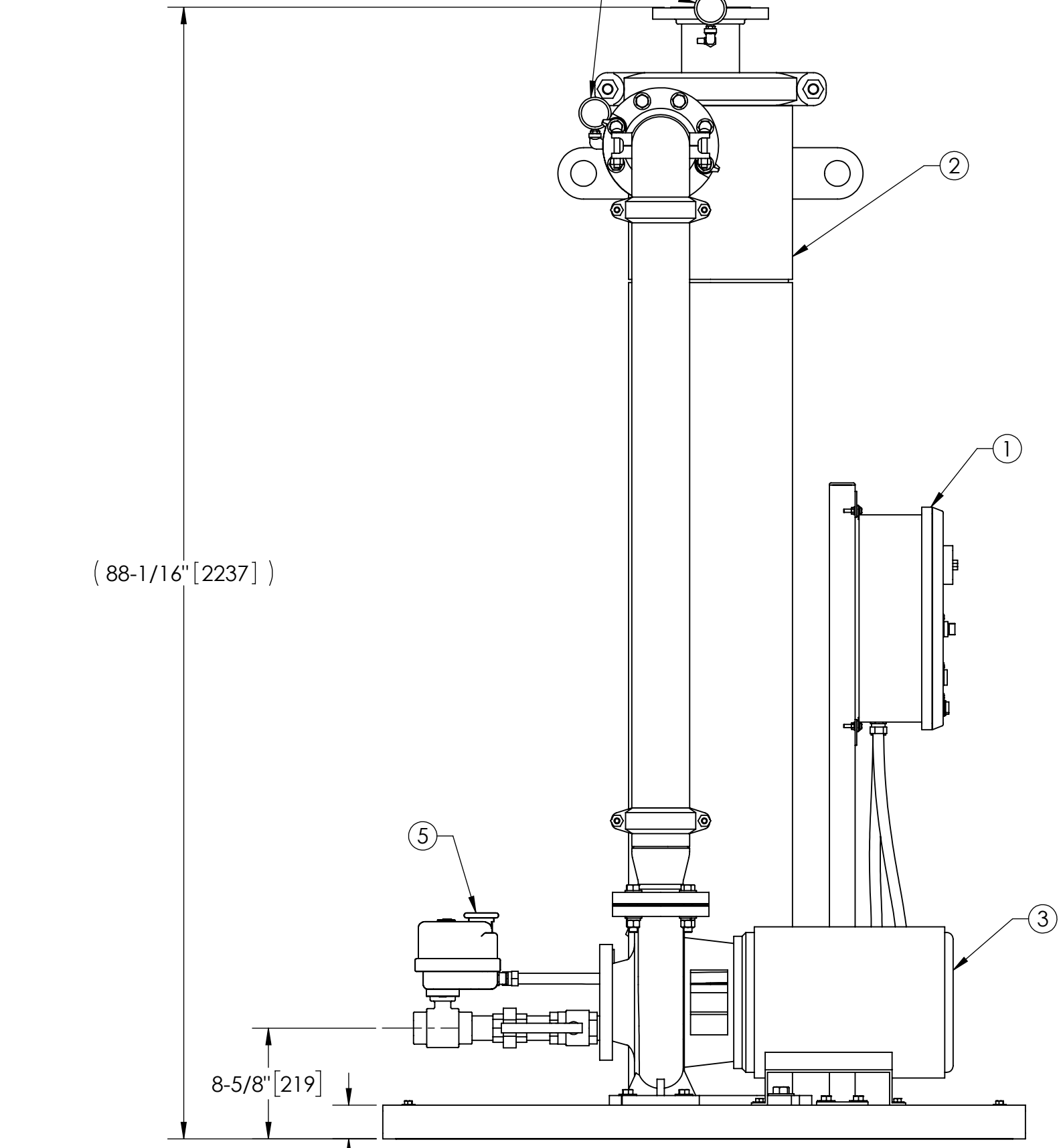

FRONT VIEW W/O STRAINER

|  |            |                             |                                     |                  |                |
|--|------------|-----------------------------|-------------------------------------|------------------|----------------|
| UNLESS OTHERWISE SPECIFIED:<br>DIMENSIONS ARE IN: INCHES (mm)<br>TOLERANCES ARE:<br>FRACTIONS DECIMALS ANGLES<br>± 1" .XX ± .01 ± 1/4"<br>.XXX ± .005<br>.XXXX ± .0005 |            | ENGINEERED FOR:<br>STANDARD |                                     |                  |                |
| DO NOT SCALE DRAWING   | APPROVALS  | DATE                        | TITLE                               |                  |                |
| MATERIAL PER LAKOS SPEC  | DRAWN TPF  | 2/25/21                     | eJCX-0410-EFS, JC SYSTEM            |                  |                |
| FINISH AS ASSEMBLED  | ENGR -     | -                           | HI EFF SWEEPER eJPX-0250, 3/60/460V |                  |                |
|  | REVIEW -   | -                           | SIZE C                              | MODEL NO.        | DWG NO. 185148 |
|  | WORK ORDER | QTY.                        | SCALE 1:10                          | EST. WT. 1322 lb | SHEET 1 OF 1   |

DWG NO. 185148 SHEET 1 REV. 01