

EXCEPT AS OTHERWISE PROVIDED BY CONTRACT, THIS DRAWING AND SPECIFICATIONS SHALL NOT BE REPRODUCED, COPIED OR USED AS THE BASIS FOR MANUFACTURE OR SALE OF MATTER DEPICTED HEREIN WITHOUT THE EXPRESSED WRITTEN PERMISSION OF THE LAKOS CORPORATION, OR ITS ASSIGNEES.

THIS DRAWING HAS BEEN GENERATED AND IS MAINTAINED BY A CAD SYSTEM. CHANGES SHALL ONLY BE INCORPORATED AS DIRECTED BY AN APPROVED ENGINEERING CHANGE ORDER (ECO). PAPER COPIES ARE UNCONTROLLED.

REVISION HISTORY				
ZONE	REV	DESCRIPTION	DATE	APPROVED
	01	RELEASED FOR SUBMITTAL	4/16/21	TPF

NOTES:

- INLET IS 8" PIPE (125# ANSI FLANGED).
- OUTLET IS 6" PIPE (150# ANSI FLANGED).
- PURGE OUTLET IS 1-1/2" PIPE.
- MAXIMUM PRESSURE: 150 psi (10.3 bar).
- MAXIMUM FLUID OPERATING TEMPERATURE: 100°F (37.8°C).
- SPECIFIED FLOWRATE OF 910 gpm (207 m³/hr).
- FINISH: AS ASSEMBLED.
- POWER REQUIREMENT: 3/60/460V.
- NEMA 4X MOTOR STARTER ENCLOSURE WITH SAFETY DISCONNECT AND H.O.A. SWITCH.
- APPROXIMATE DRY WEIGHT: 2776 lbs (1259 kg).
- INLET/OUTLET VALVE KIT RECOMMENDED: SEE FACTORY.
- MINIMUM PIPE FROM TOWER BASIN TO JC SYSTEM IS 8" PIPE.
- FLOODED SUCTION REQUIRED.

COMPONENT LIST:

- ELECTRICAL CONTROL BOX 3/60/460V W/120V TRANSFORMER.
- SEPARATOR: eJPX-0425-L.
- PUMP: 25 HP CENTRIFUGAL, 1770 rpm, 3/60/460V.
- INLET/OUTLET PRESSURE GAUGES: 0-160 psi, GLYCERIN-FILLED.
- PURGE EQUIPMENT: SRV-833.
- DIFFERENTIAL PRESSURE INDICATOR: (AVAILABLE WITH DRY ELECTRICAL CONTACT - MODEL DHE-15-S. ORDER SEPARATELY).
- STRAINER, SUCTION DIFFUSER (DIFFUSER SUPPORT WILL NOT BE SUPPLIED BY LAKOS).

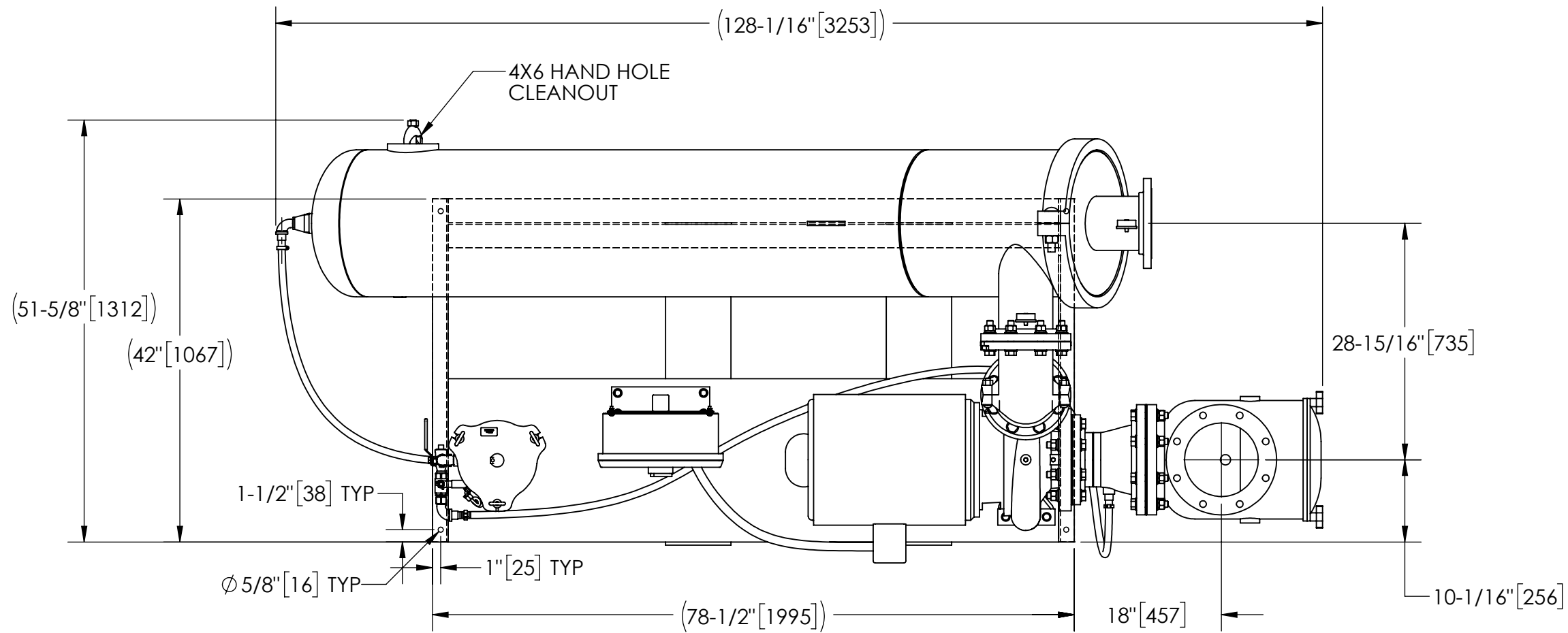

TOP VIEW

SUBMITTAL DRAWING

This drawing is submitted for spatial consideration only. Do not pre-plumb to these dimensions.

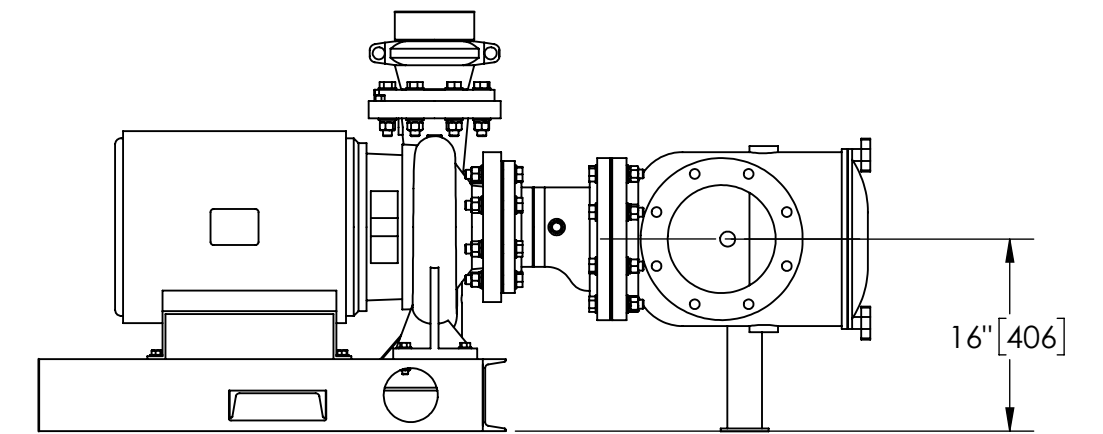

FRONT VIEW ROTATED STRAINER (OPTIONAL)

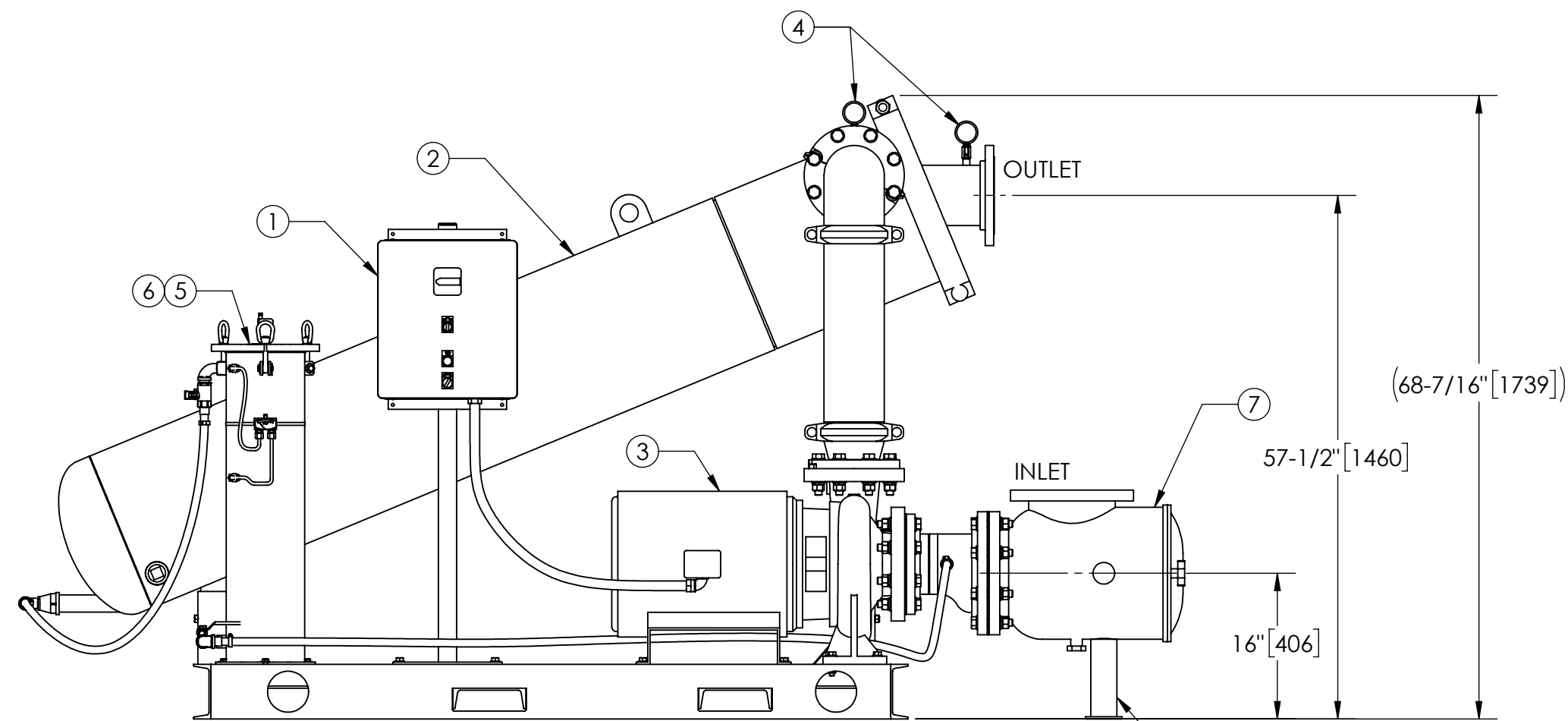

FRONT VIEW

DIFFUSER SUPPORT WILL NOT BE SUPPLIED BY LAKOS

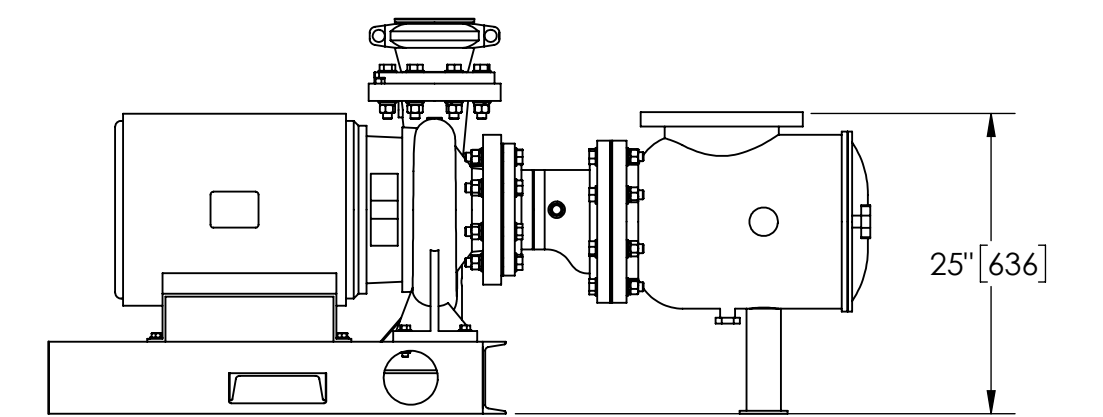

FRONT VIEW PUMP & STRAINER

UNLESS OTHERWISE SPECIFIED: DIMENSIONS ARE IN: INCHES (mm) TOLERANCES ARE: FRACTIONS    DECIMALS    ANGLES ± 1"            .XX ± .01            ± 1/4" .XXX ± .005            .XXXX ± .0005	ENGINEERED FOR:		FRESNO, CALIFORNIA WWW.LAKOS.COM					
	STANDARD							
	DO NOT SCALE DRAWING	APPROVALS	DATE	TITLE eJCX-0910-SRV, JC SYSTEM HI EFF SWEEPER eJPX-0425, 3/60/460V				
	MATERIAL	ENGR						
FINISH	REVIEW		SIZE	MODEL NO.	DWG NO.	REV.		
AS ASSEMBLED	WORK ORDER		C		185243	01		
			SCALE	1:16	EST. WT.	2776 lb	SHEET	1 OF 1

DWG NO. 185243  
SHEET 1 OF 1  
REV. 01