

EXCEPT AS OTHERWISE PROVIDED BY CONTRACT, THIS DRAWING AND SPECIFICATIONS SHALL NOT BE REPRODUCED, COPIED OR USED AS THE BASIS FOR MANUFACTURE OR SALE OF MATTER DEPICTED HEREIN WITHOUT THE EXPRESSED WRITTEN PERMISSION OF THE LAKOS CORPORATION, OR ITS ASSIGNEES.

THIS DRAWING HAS BEEN GENERATED AND IS MAINTAINED BY A CAD SYSTEM. CHANGES SHALL ONLY BE INCORPORATED AS DIRECTED BY AN APPROVED ENGINEERING CHANGE ORDER (ECO). PAPER COPIES ARE UNCONTROLLED.

REVISION HISTORY				
ZONE	REV	DESCRIPTION	DATE	APPROVED
	01	RELEASED FOR SUBMITTAL	4/16/21	TPF

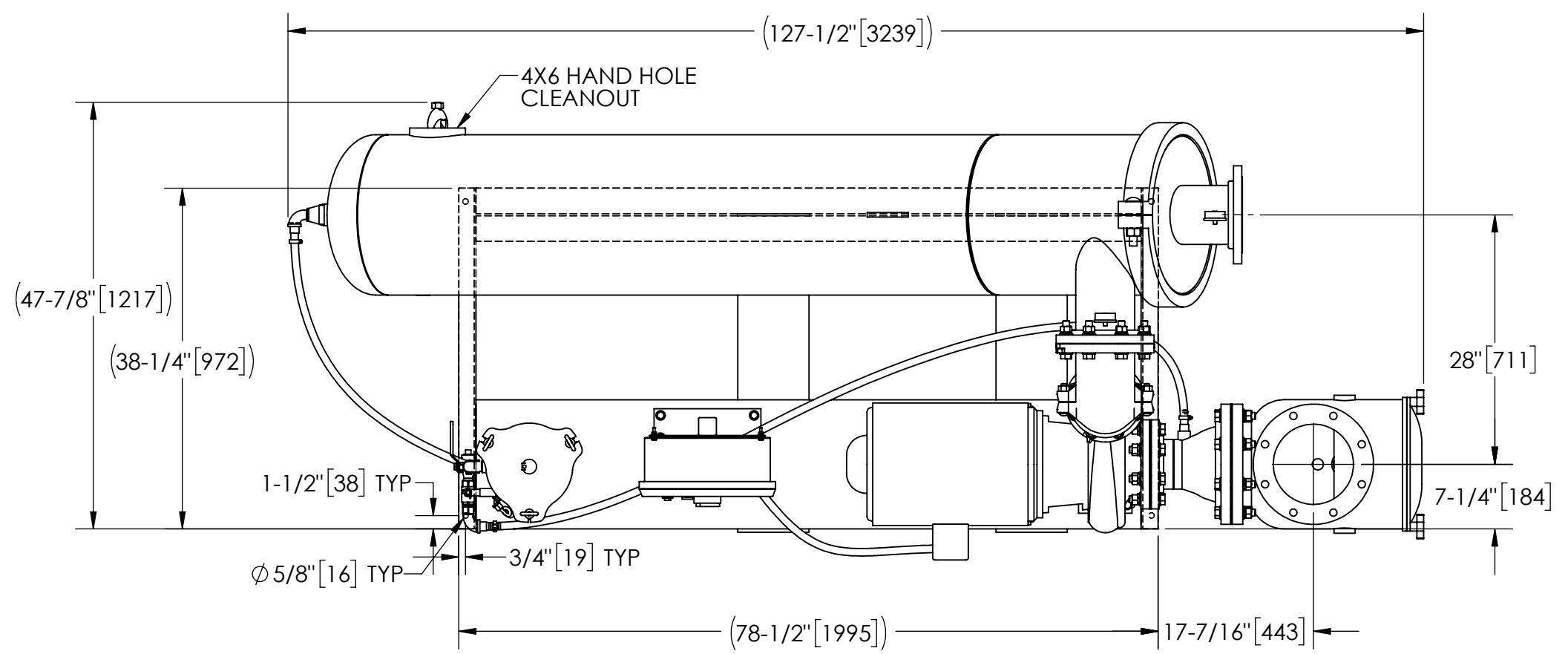

TOP VIEW

SUBMITTAL DRAWING

This drawing is submitted for spatial consideration only. Do not pre-plumb to these dimensions.

NOTES:

1. INLET IS 8" PIPE (125# ANSI FLANGED).
2. OUTLET IS 6" PIPE (150# ANSI FLANGED).
3. PURGE OUTLET IS 1-1/2" PIPE.
4. MAXIMUM PRESSURE: 150 psi (10.3 bar).
5. MAXIMUM FLUID OPERATING TEMPERATURE: 100°F (37.8°C).
6. SPECIFIED FLOWRATE: 810 gpm (184 m³/hr).
7. FINISH: AS ASSEMBLED.
8. POWER REQUIREMENT: 3/60/460V.
9. NEMA 4X MOTOR STARTER ENCLOSURE WITH SAFETY DISCONNECT AND H.O.A. SWITCH.
10. APPROXIMATE DRY WEIGHT: 2397 lbs (1087 kg).
11. INLET/OUTLET VALVE KIT RECOMMENDED: SEE FACTORY.
12. MINIMUM PIPE FROM TOWER BASIN TO JC SYSTEM IS 8" PIPE.
13. FLOODED SUCTION REQUIRED.

COMPONENT LIST:

- ① ELECTRICAL CONTROL BOX 3/60/460V W/120V TRANSFORMER.
- ② SEPARATOR: eJPX-0425-L.
- ③ PUMP: 15 HP CENTRIFUGAL, 1760 rpm, 3/60/460V.
- ④ INLET/OUTLET PRESSURE GAUGES: 0-160 psi, GLYCERIN-FILLED.
- ⑤ PURGE EQUIPMENT: SRV-833.
- ⑥ DIFFERENTIAL PRESSURE INDICATOR: (AVAILABLE WITH DRY ELECTRICAL CONTACT - MODEL DHE-15-S. ORDER SEPARATELY).
- ⑦ STRAINER, SUCTION DIFFUSER (DIFFUSER SUPPORT WILL NOT BE SUPPLIED BY LAKOS)

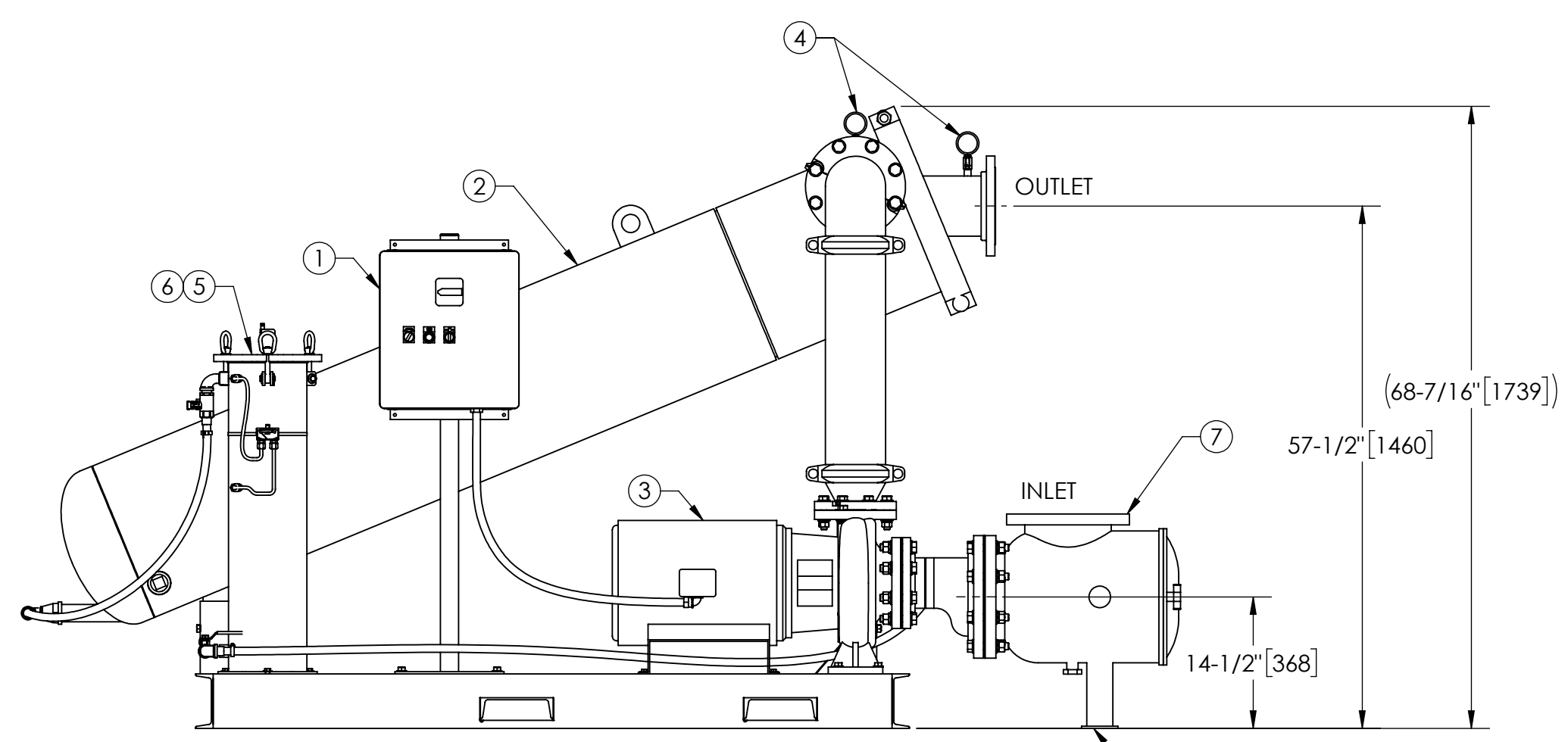

FRONT VIEW

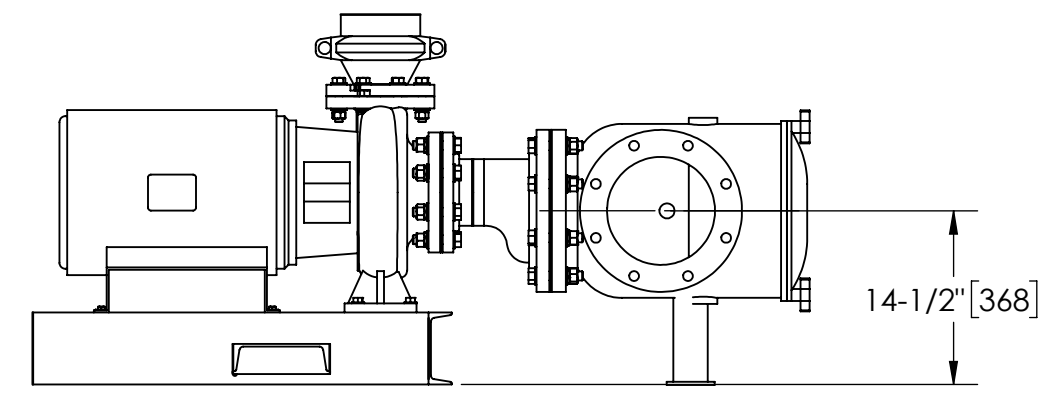

FRONT VIEW ROTATED STRAINER (OPTIONAL)

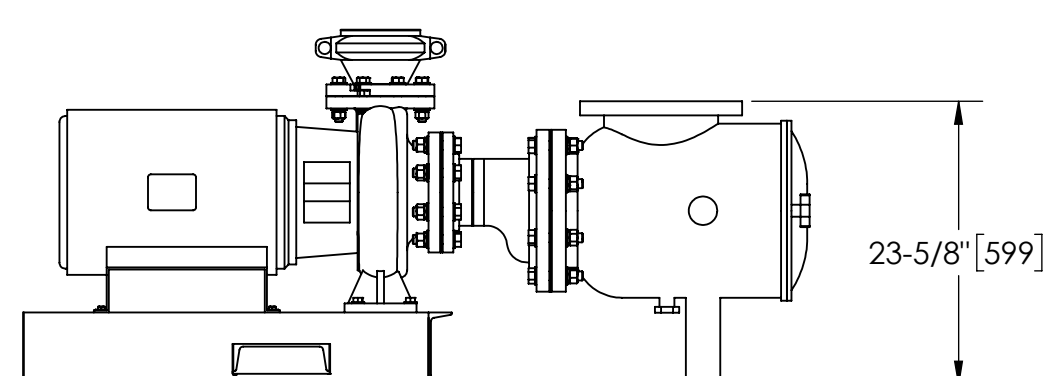

FRONT VIEW PUMP & STRAINER

UNLESS OTHERWISE SPECIFIED: DIMENSIONS ARE IN: INCHES (mm) TOLERANCES ARE: FRACTIONS DECIMALS ANGLES ± 1" .XX ± .01 ± 1/4° .XXX ± .005 .XXXX ± .0005	ENGINEERED FOR:		FRESNO, CALIFORNIA WWW.LAKOS.COM	
	STANDARD			
	APPROVALS	DATE	TITLE	
	DRAWN	TPF	4/16/21	eJBX-0810-SRV, JC SYSTEM HI EFF SIDESTRM eJPX-0425, 3/60/460V
MATERIAL	ENGR	-	SIZE	MODEL NO.
PER LAKOS SPEC	MFG	-	C	
FINISH	WORK ORDER		SCALE	DWG NO.
AS ASSEMBLED			1:16	185246
			EST. WT.	SHEET
			2397	1 OF 1
			REV.	
				01

DWG. NO. 185246
 SHEET 1 OF 1
 REV. 01