

4

3

2

1

EXCEPT AS OTHERWISE PROVIDED BY CONTRACT, THIS DRAWING AND SPECIFICATIONS SHALL NOT BE REPRODUCED, COPIED OR USED AS THE BASIS FOR MANUFACTURE OR SALE OF MATTER DEPICTED HEREIN WITHOUT THE EXPRESSED WRITTEN PERMISSION OF THE LAKOS CORPORATION, OR ITS ASSIGNEES.

THIS DRAWING HAS BEEN GENERATED AND IS MAINTAINED BY A CAD SYSTEM. CHANGES SHALL ONLY BE INCORPORATED AS DIRECTED BY AN APPROVED ENGINEERING CHANGE ORDER (ECO). PAPER COPIES ARE UNCONTROLLED.

| REVISIONS | | | | |
|-----------|------|-------------|------|----------|
| ZONE | REV. | DESCRIPTION | DATE | APPROVED |
| | | | | |

NOTES:

1. INLET IS 3" PIPE (125# ANSI FLANGED).
2. OUTLET IS 3" PIPE (GROOVED).
3. PURGE OUTLET IS 3/4" NPT.
4. MAXIMUM PRESSURE: 150 psi (10.3 bar).
5. MAXIMUM FLUID TEMPERATURE: 140°F (60°C).
6. SPECIFIED FLOWRATE OF 200 gpm (45 m³/hr).
7. FINISH: AS ASSEMBLED.
8. POWER REQUIREMENT: 3/60/460V.
9. NEMA 4X MOTOR STARTER ENCLOSURE WITH SAFETY DISCONNECT AND H.O.A. SWITCH.
10. APPROXIMATE DRY WEIGHT: 439 lbs (199 kg).
11. INLET/OUTLET VALVE KIT, MODEL TCV-0200 RECOMMENDED.
12. MINIMUM PIPE FROM TOWER BASIN TO TC SYSTEM IS 4" PIPE.
13. FLOODED SUCTION REQUIRED.

COMPONENT LIST

- 1 ELECTRICAL CONTROL BOX: 3/60/460V, W/120V TRANSFORMER.
- 2 SEPARATOR: ILB-0300.
- 3 PUMP: 7.5 HP, CENTRIFUGAL, TEFC, 3500 rpm, 3/60/460V.
- 4 INLET/OUTLET PRESSURE GAUGES: 0-160 psi, GLYCERIN-FILLED.
- 5 PURGE EQUIPMENT: ABV2-07-120V.
- 6 BASKET STRAINER.

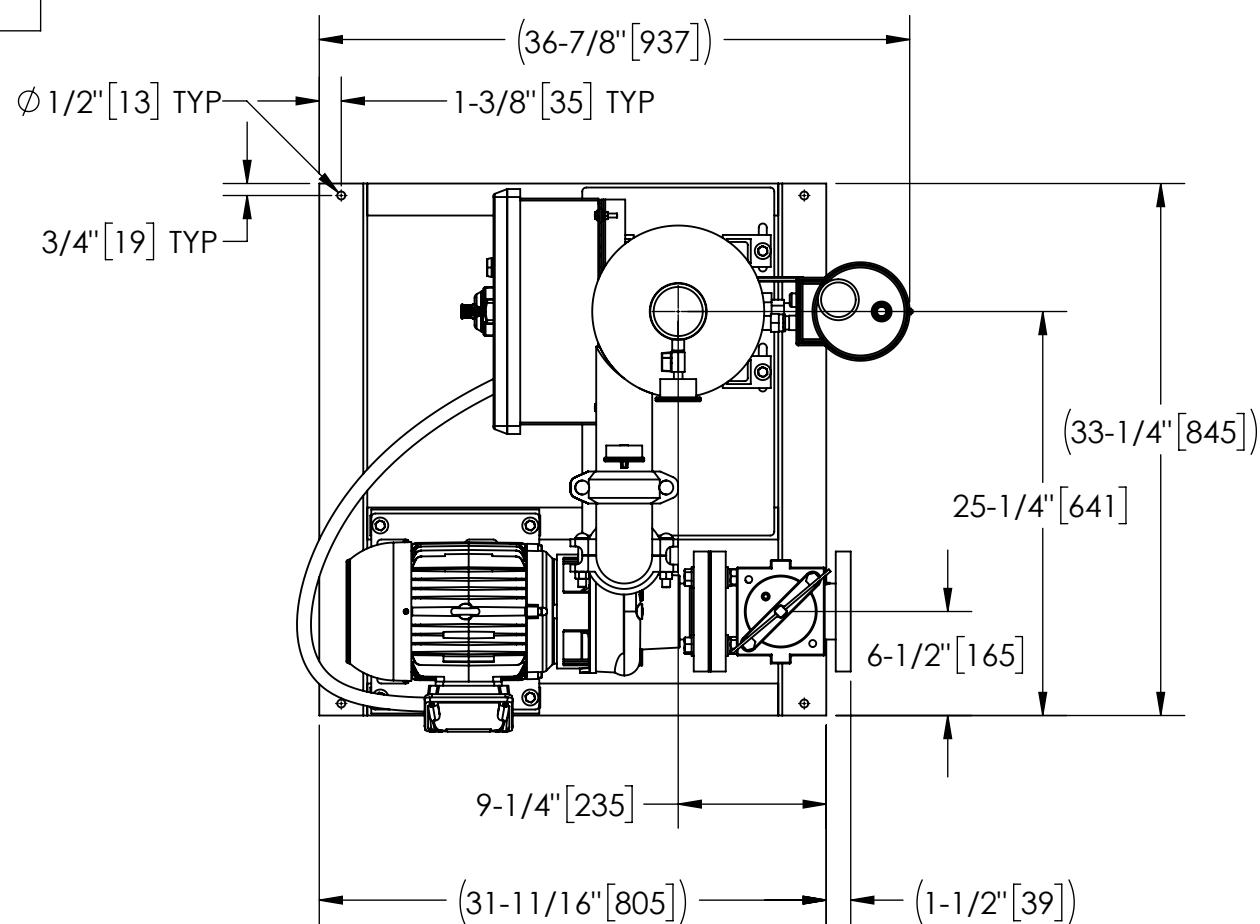

TOP VIEW

CONCEPTUAL DRAWING

This drawing is submitted for spatial & illustrative purposes only. Do not pre-plumb to these dimensions. Submittal drawings available upon request.

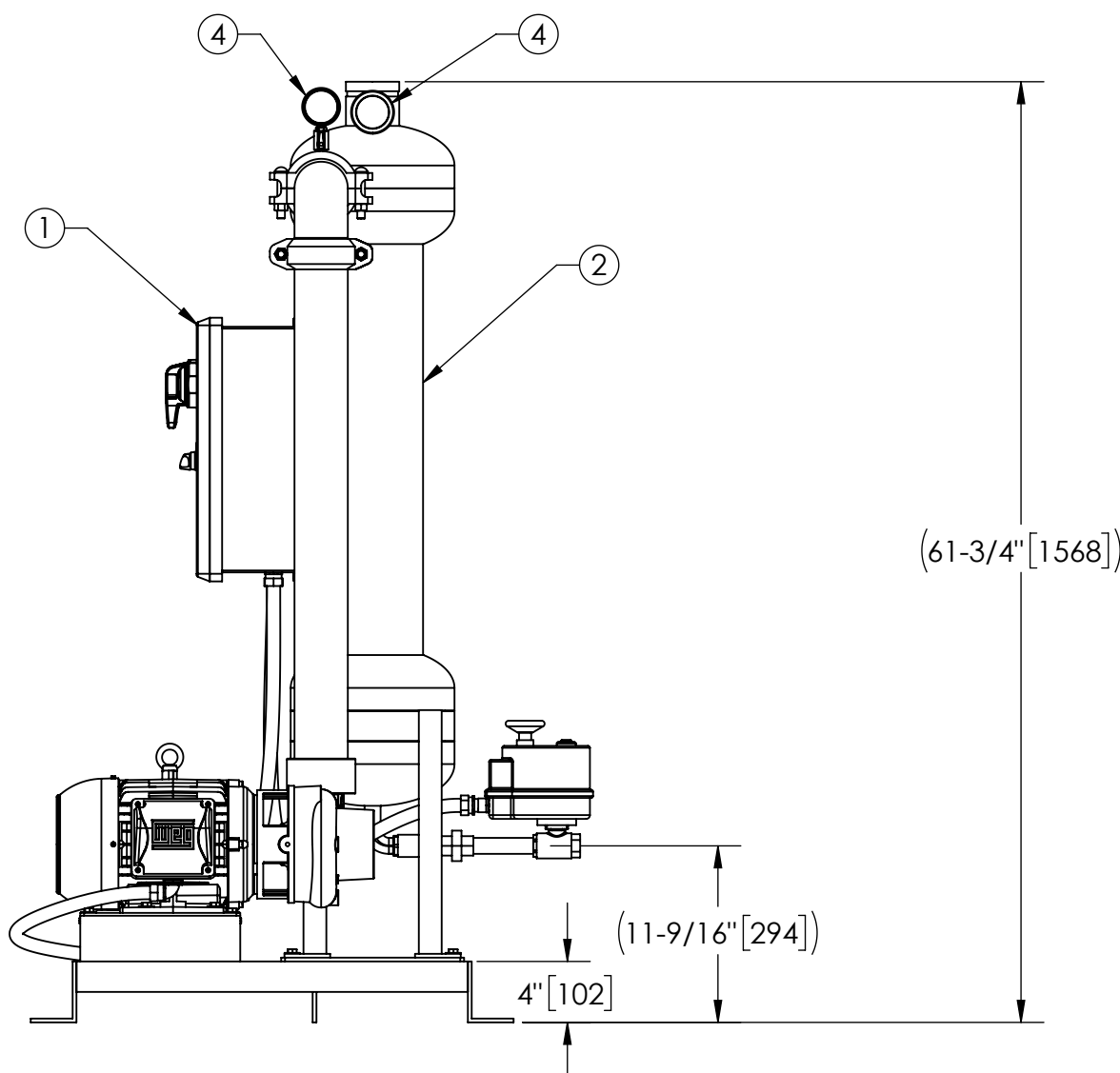
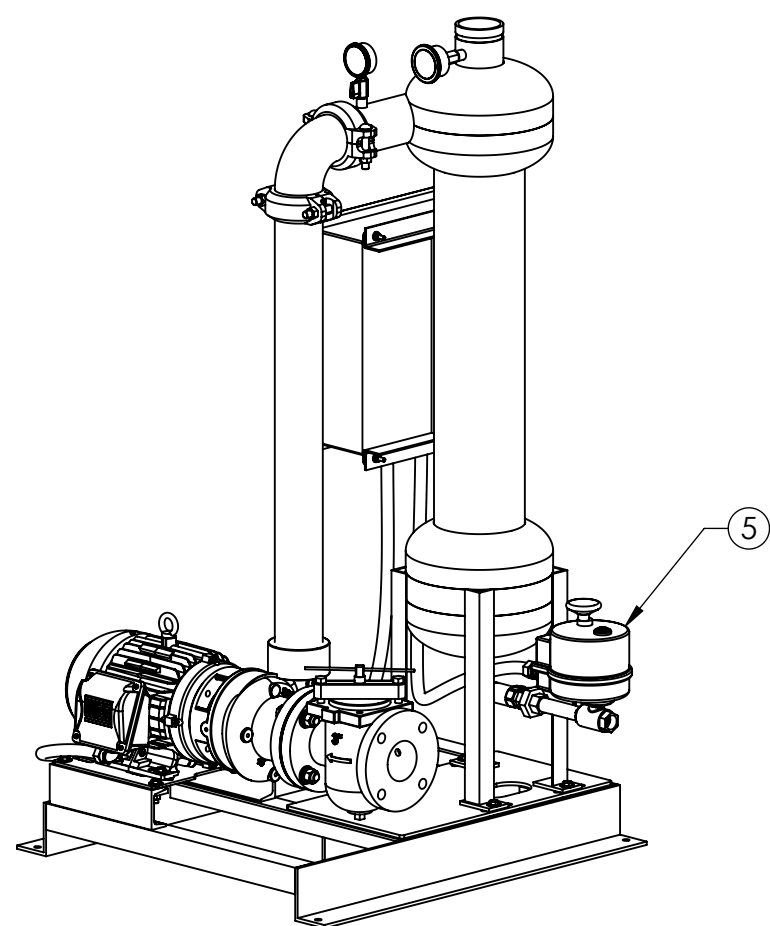

FRONT VIEW
STRAINER HIDDEN

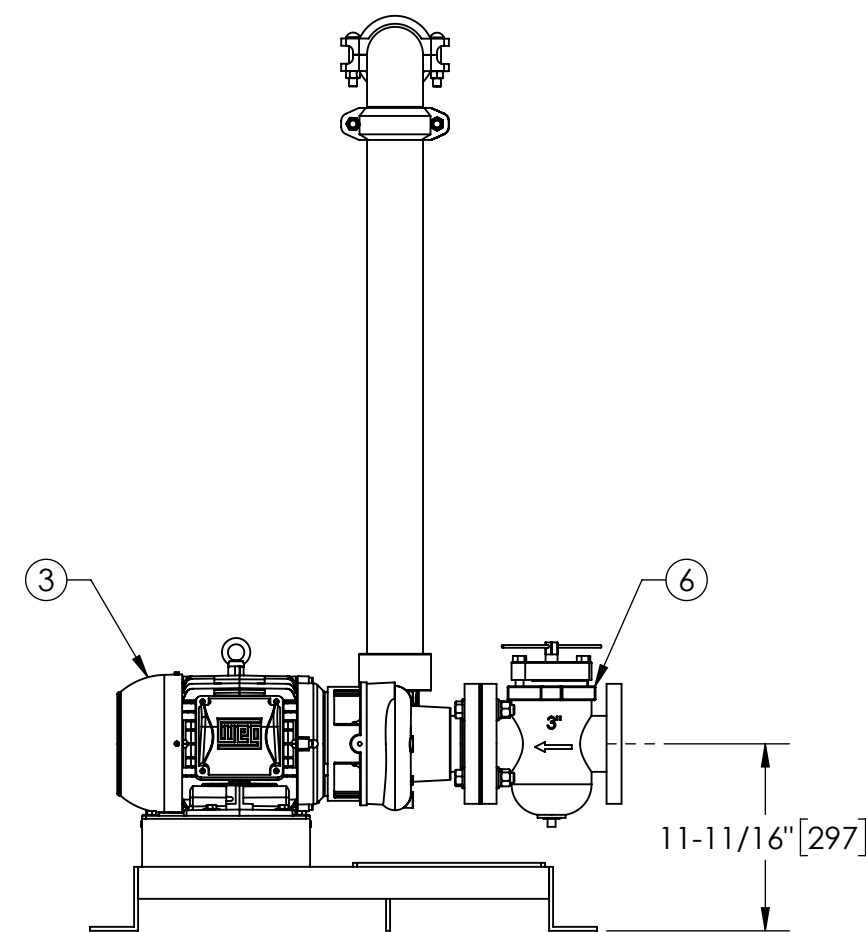

FRONT VIEW
PUMP & STRAINER

| SYSTEM MODELS | |
|-------------------|-----------------|
| POWER REQUIREMENT | SYSTEM PART NO. |
| 3/60/208V | 187702-208 |
| 3/60/230V | 187702-230 |
| 3/60/460V | 187702-460 |
| 3/60/575V | 187702-575 |
| OTHER | SEE FACTORY |

| | | | | | |
|--|--|-----------------------------|--------|---|-----------------|
| UNLESS OTHERWISE SPECIFIED: DIMENSIONS ARE IN: INCHES (mm) TOLERANCES ARE: FRACTIONS DECIMALS ANGLES ± 1" .XX ± .01 ± 1/4" XXX ± .005 XXXX ± .0005 | | ENGINEERED FOR: STANDARD | |  | |
| DO NOT SCALE DRAWING | | APPROVALS | DATE | TITLE | |
| MATERIAL PER LAKOS SPEC | | DRAWN AAM | 2/6/24 | TCI-0200-ABV/CS SKID, TC SYSTEM, SWEEPER ILB-0300, 3/60/460V | |
| FINISH AS ASSEMBLED | | ENGR - | - | SIZE C | MODEL NO. |
| WORK ORDER | | REVIEW - | - | DWG NO. 187702 | REV. A |
| | | SCALE 1:12 | QTY. | EST. WT. 439 lb | SHEET 1 OF 1 |

4

3

2

1

DWG NO. 187702
 SH 1
 REV. A