

EXCEPT AS OTHERWISE PROVIDED BY CONTRACT, THIS DRAWING AND SPECIFICATIONS SHALL NOT BE REPRODUCED, COPIED OR USED AS THE BASIS FOR MANUFACTURE OR SALE OF MATTER DEPICTED HEREIN WITHOUT THE EXPRESSED WRITTEN PERMISSION OF THE CLAUDE LAVAL CORPORATION, OR ITS ASSIGNEES.

THIS DRAWING HAS BEEN GENERATED AND IS MAINTAINED BY A CAD SYSTEM. CHANGES SHALL ONLY BE INCORPORATED AS DIRECTED BY AN APPROVED ENGINEERING CHANGE ORDER (ECO). PAPER COPIES ARE UNCONTROLLED.

REVISION HISTORY				
ZONE	REV	DESCRIPTION	DATE	APPROVED

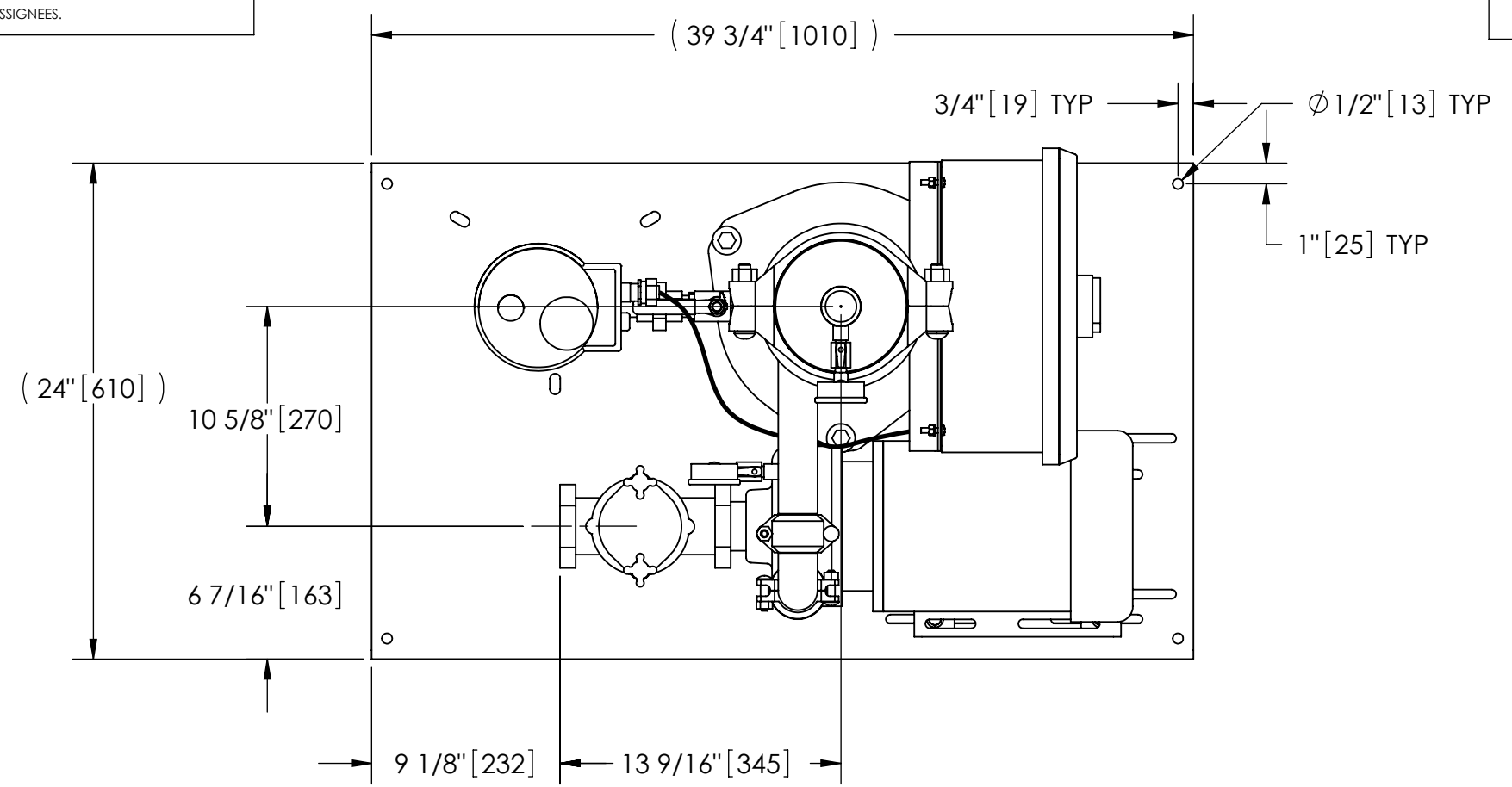

TOP VIEW

NOTES:

1. INLET IS 2" PIPE (NPT).
2. OUTLET IS 1-1/2" PIPE (GROOVED).
3. PURGE OUTLET IS 3/4" PIPE.
4. MAXIMUM PRESSURE: 150 psi (10.3 bar).
5. MAXIMUM TEMPERATURE: 100°F (37.8°C).
6. SPECIFIED FLOWRATE OF 65 gpm (15 m³/hr).
7. FINISH: AS ASSEMBLED.
8. POWER REQUIREMENT: 460V, 3PH, 60Hz.
9. NEMA 4X MOTOR STARTER ENCLOSURE WITH SAFETY DISCONNECT AND H.O.A. SWITCH.
10. APPROXIMATE DRY WEIGHT: 386 lbs (175 kg).
11. INLET/OUTLET VALVE KIT, MODEL TCV-0065 RECOMMENDED.
12. MINIMUM PIPE FROM TOWER BASIN TO TC SYSTEM IS 2-1/2" PIPE.
13. FLOODED SUCTION REQUIRED.

COMPONENT LIST:

- 1 ELECTRICAL CONTROL BOX 460V 60Hz W/120V TRANSFORMER.
- 2 SEPARATOR: HTX-0038-TC.
- 3 PUMP: 3 HP CENTRIFUGAL, 3500 rpm, 460V, 60Hz.
- 4 INLET/OUTLET PRESSURE GAUGES: 0-100 psi, GLYCERIN-FILLED.
- 5 PURGE EQUIPMENT: ABV-07-120V.
- 6 STRAINER

SUBMITTAL DRAWING

This drawing is submitted for spatial consideration only. Do not pre-plumb to these dimensions.

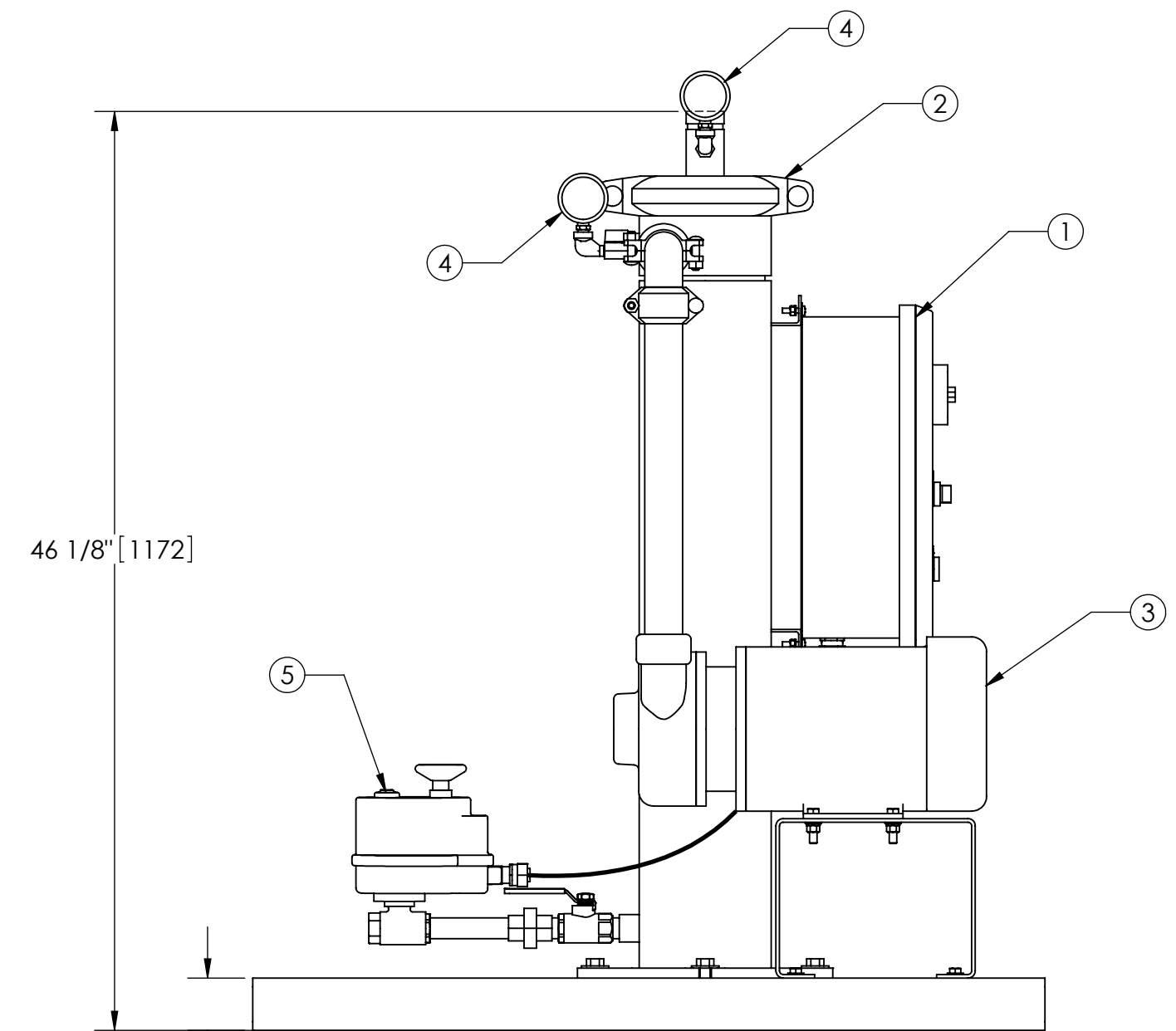

FRONT VIEW W/O STRAINER

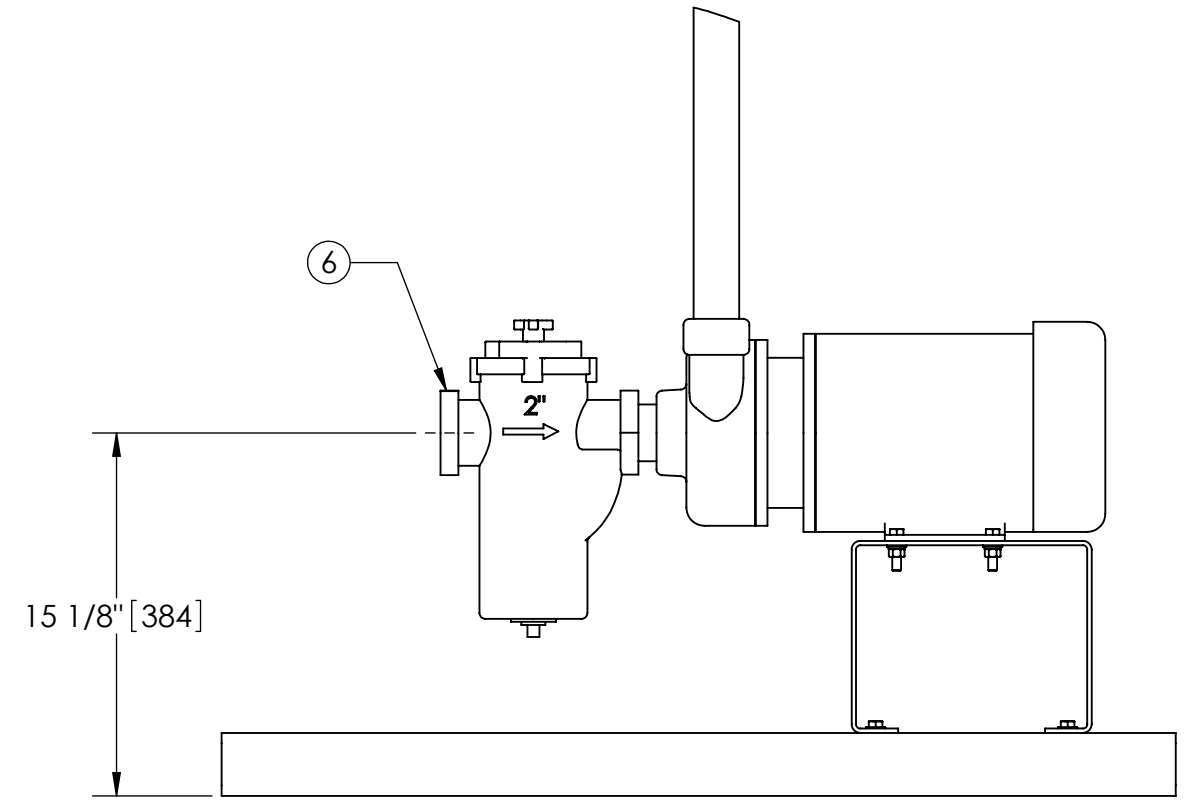

FRONT VIEW PUMP & STRAINER

UNLESS OTHERWISE SPECIFIED: DIMENSIONS ARE IN: INCHES (mm) TOLERANCES ARE: FRACTIONS DECIMALS ANGLES ± 1/2" .XX ± .01 ± 1/4" .XXX ± .005 .XXXX ± .0005	ENGINEERED FOR: STANDARD		CLAUDE LAVAL CORP. FRESNO, CALIFORNIA 93727 WWW.LAKOS.COM	LAVAL UNDERGROUND SURVEYS					
	APPROVALS	DATE							
DO NOT SCALE DRAWING	DRAWN	SUB/ADJ	5/25/05	TITLE TCX-0065-ABV, TC SYSTEM, SWEEPER HTX-0038, 460V 60HZ DELUXE					
MATERIAL	ENGR	HSK	5/25/05						
FINISH	MFG	-	-	SIZE	MODEL NO.	DWG NO.	122727	REV.	B
AS ASSEMBLED	WORK ORDER	-	-	SCALE	1:8	EST. WT.	386 lb	SHEET	1 OF 1

DWG. NO. 122727
 SHEET B