

EXCEPT AS OTHERWISE PROVIDED BY CONTRACT, THIS DRAWING AND SPECIFICATIONS SHALL NOT BE REPRODUCED, COPIED OR USED AS THE BASIS FOR MANUFACTURE OR SALE OF MATTER DEPICTED HEREIN WITHOUT THE EXPRESSED WRITTEN PERMISSION OF THE CLAUDE LAVAL CORPORATION, OR ITS ASSIGNEES.

THIS DRAWING HAS BEEN GENERATED AND IS MAINTAINED BY A CAD SYSTEM. CHANGES SHALL ONLY BE INCORPORATED AS DIRECTED BY AN APPROVED ENGINEERING CHANGE ORDER (ECO). PAPER COPIES ARE UNCONTROLLED.

REVISION HISTORY				
ZONE	REV	DESCRIPTION	DATE	APPROVED

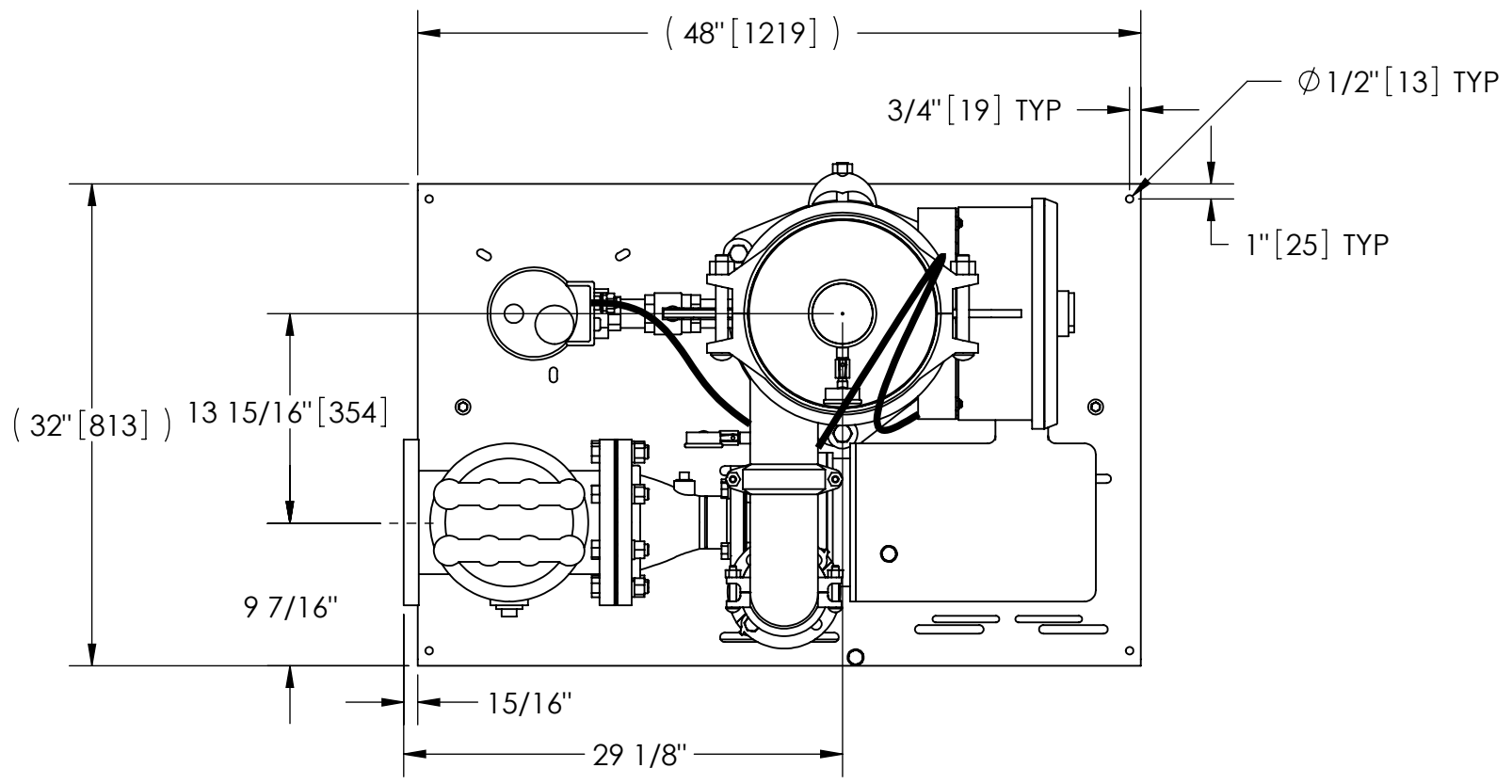

TOP VIEW

NOTES:

1. INLET IS 6" PIPE (125# ANSI FLANGED).
2. OUTLET IS 4" PIPE (GROOVED).
3. PURGE OUTLET IS 1-1/2" PIPE.
4. MAXIMUM PRESSURE: 150 psi (10.3 bar).
5. MAXIMUM TEMPERATURE: 100°F (37.8°C).
6. SPECIFIED FLOWRATE OF 400 gpm (91 m³/hr).
7. FINISH: AS ASSEMBLED.
8. POWER REQUIREMENT: 460V, 3PH, 60Hz.
9. NEMA 4X MOTOR STARTER ENCLOSURE WITH SAFETY DISCONNECT AND H.O.A. SWITCH.
10. APPROXIMATE DRY WEIGHT: 1067 lbs (478 kg).
11. INLET/OUTLET VALVE KIT, MODEL TCX-0400 RECOMMENDED.
12. MINIMUM PIPE FROM TOWER BASIN TO TC SYSTEM IS 6" PIPE.
13. FLOODED SUCTION REQUIRED.

COMPONENT LIST:

- ① ELECTRICAL CONTROL BOX 460V 60Hz W/115V TRANSFORMER.
- ② SEPARATOR: HTX-0285-TC.
- ③ PUMP: 15 HP CENTRIFUGAL, 3500 rpm, 460V, 60Hz.
- ④ INLET/OUTLET PRESSURE GAUGES: 0-100 psi, GLYCERIN-FILLED.
- ⑤ PURGE EQUIPMENT: ABV-15-120V.
- ⑥ BASKET STRAINER.

SUBMITTAL DRAWING

This drawing is submitted for spatial consideration only. Do not pre-plumb to these dimensions.

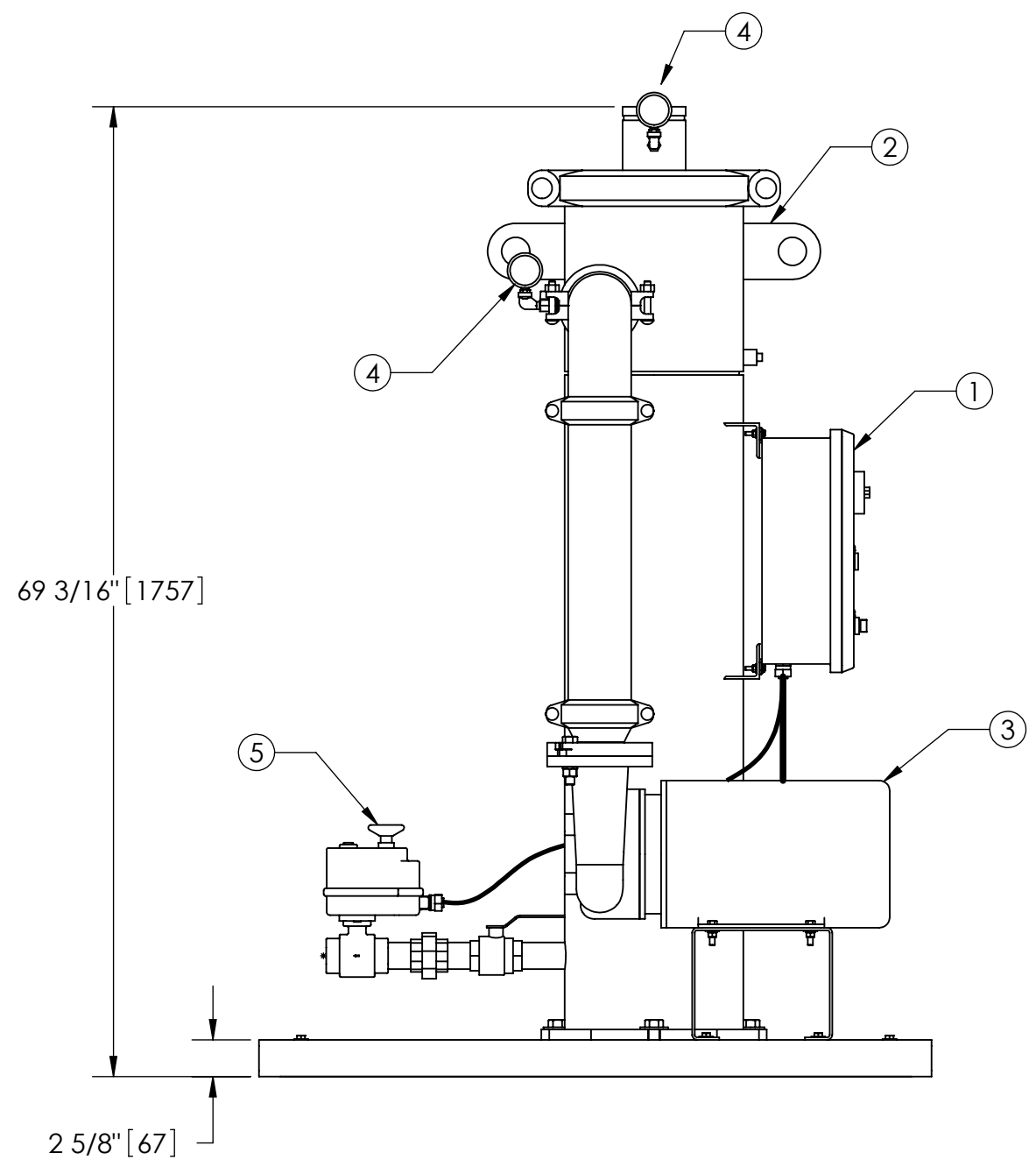

FRONT VIEW W/O STRAINER

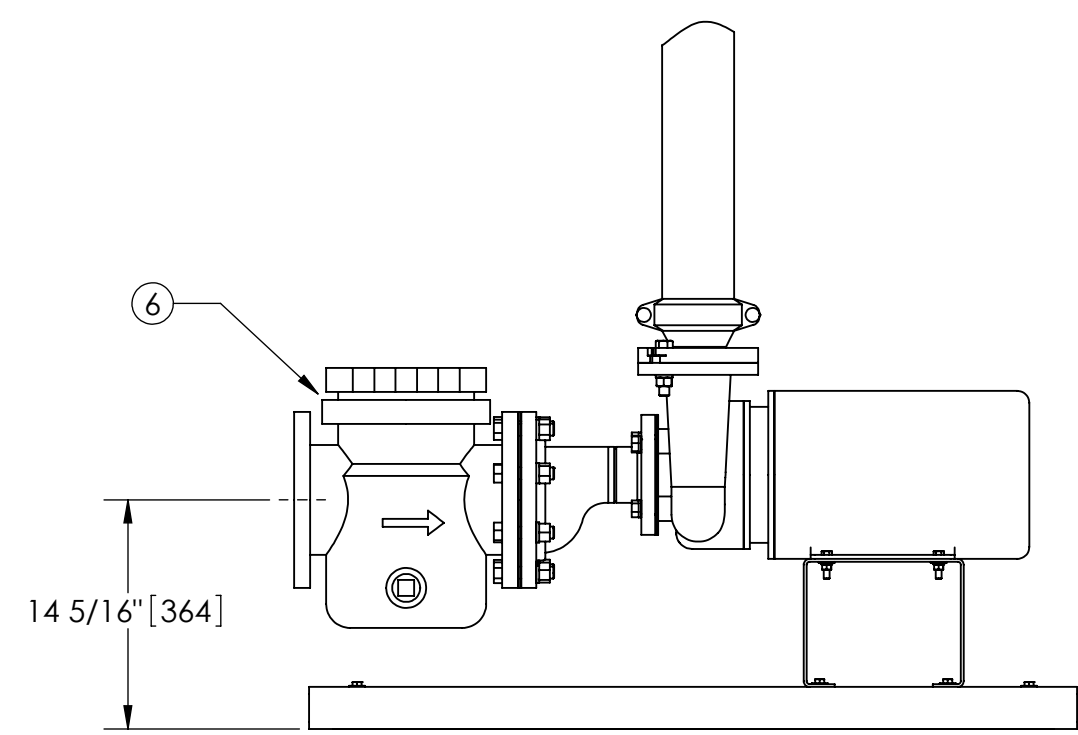

FRONT VIEW PUMP & STRAINER

<small>UNLESS OTHERWISE SPECIFIED: DIMENSIONS ARE IN: INCHES (mm) TOLERANCES ARE: FRACTIONS DECIMALS ANGLES ± 1/2" .XX ± .01 ± 1/4" .XXX ± .005 .XXXX ± .0005</small>	ENGINEERED FOR: STANDARD			<small>CLAUDE LAVAL CORP. FRESNO, CALIFORNIA 93727 WWW.LAKOS.COM</small>		
	APPROVALS	DATE		TITLE		
	DO NOT SCALE DRAWING	DRAWN TOM C./HSK	5/23/05	TCX-0400-ABV, TC SYSTEM, SWEEPER HTX-0285, 460V 60HZ DELUXE		
	MATERIAL PER LAKOS SPEC	ENGR DLW	7/18/05	SIZE C	MODEL NO.	DWG NO. 122732
FINISH AS ASSEMBLED	MFG -	-	SCALE 1:12	EST. WT. 1067 lb	SHEET 1 OF 1	
	WORK ORDER	QTY.				

DWG NO. 122732 SHEET REV. C