

EXCEPT AS OTHERWISE PROVIDED BY CONTRACT, THIS DRAWING AND SPECIFICATIONS SHALL NOT BE REPRODUCED, COPIED OR USED AS THE BASIS FOR MANUFACTURE OR SALE OF MATTER DEPICTED HEREIN WITHOUT THE EXPRESSED WRITTEN PERMISSION OF THE CLAUDE LAVAL CORPORATION, OR ITS ASSIGNEES.

THIS DRAWING HAS BEEN GENERATED AND IS MAINTAINED BY A CAD SYSTEM. CHANGES SHALL ONLY BE INCORPORATED AS DIRECTED BY AN APPROVED ENGINEERING CHANGE ORDER (ECO). PAPER COPIES ARE UNCONTROLLED.

REVISIONS				
ZONE	REV.	DESCRIPTION	DATE	APPROVED
-	-	-	-	-

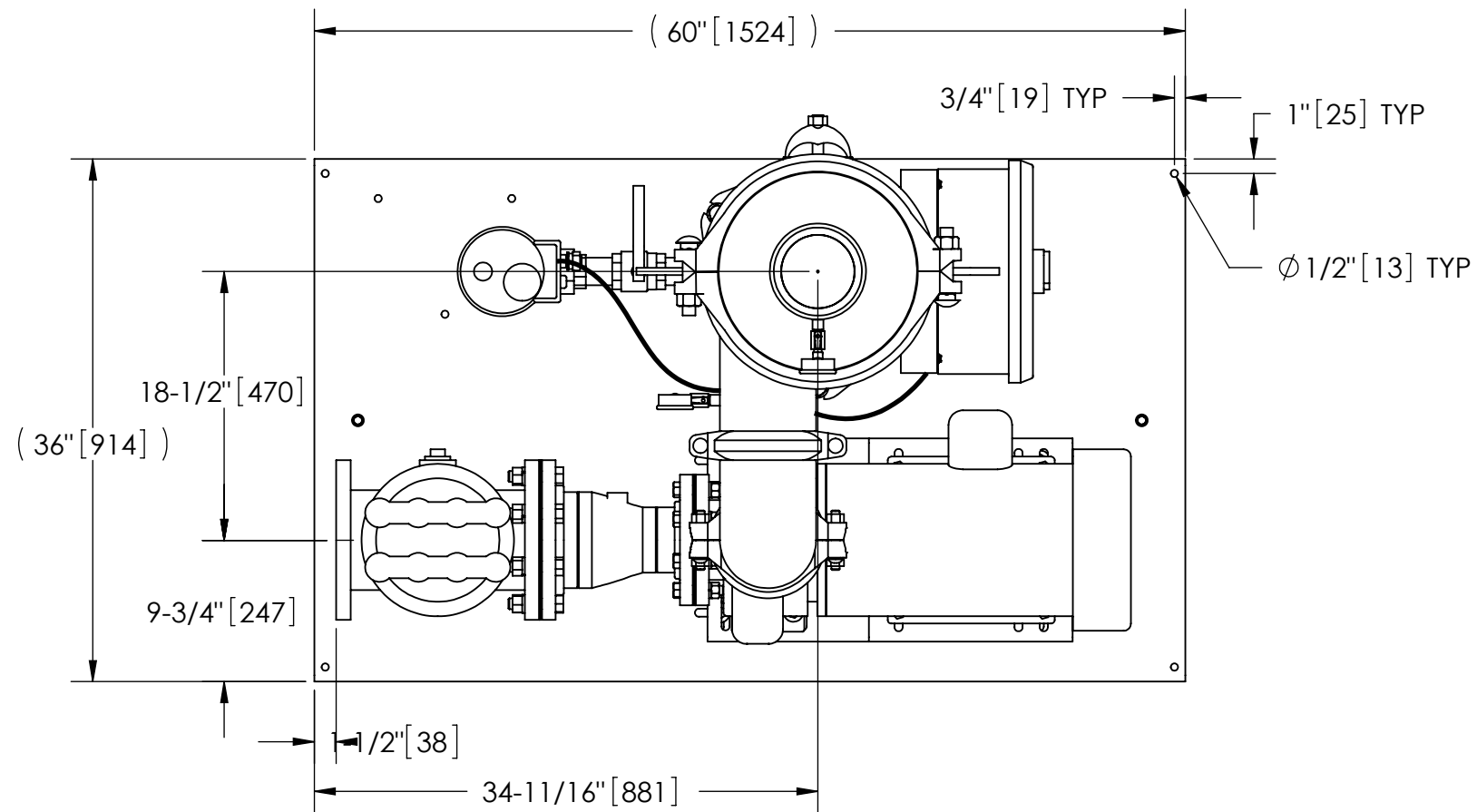

TOP VIEW

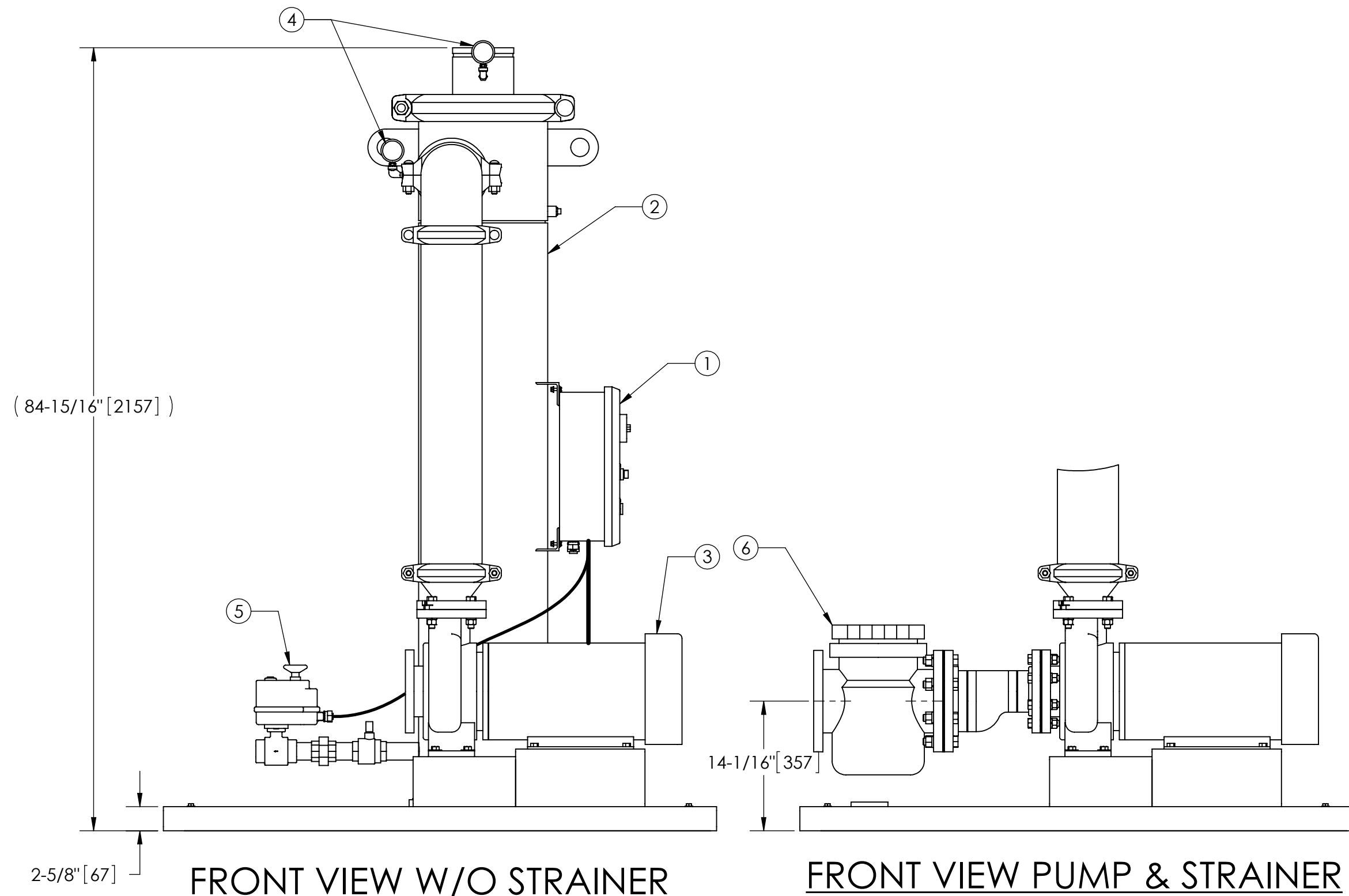

FRONT VIEW W/O STRAINER

FRONT VIEW PUMP & STRAINER

NOTES:

1. INLET IS 6" PIPE (125# ANSI FLANGED).
2. OUTLET IS 6" PIPE (GROOVED).
3. PURGE OUTLET IS 1-1/2" PIPE.
4. MAXIMUM PRESSURE: 150 psi (10.3 bar).
5. MAXIMUM TEMPERATURE: 100°F (37.8°C).
6. SPECIFIED FLOWRATE OF 600 gpm (136 m³/hr).
7. FINISH: AS ASSEMBLED.
8. POWER REQUIREMENT: 3/60/460V.
9. NEMA 4X MOTOR STARTER ENCLOSURE WITH SAFETY DISCONNECT AND H.O.A. SWITCH.
10. APPROXIMATE DRY WEIGHT: 1462 lbs (663 kg).
11. INLET/OUTLET VALVE KIT, MODEL TCV-0600 RECOMMENDED.
12. MINIMUM PIPE FROM TOWER BASIN TO TC SYSTEM IS 6" PIPE.
13. FLOODED SUCTION REQUIRED.

COMPONENT LIST:

- ① ELECTRICAL CONTROL BOX 3/60/460V W/120V TRANSFORMER.
- ② SEPARATOR: HTX-0450-TC.
- ③ PUMP: 20 HP CENTRIFUGAL, 3500 rpm, 3/60/460V.
- ④ INLET/OUTLET PRESSURE GAUGES: 0-100 psi, GLYCERIN-FILLED.
- ⑤ PURGE EQUIPMENT: ABV-15-120V.
- ⑥ BASKET STRAINER.

SUBMITTAL DRAWING

This drawing is submitted for spatial consideration only. Do not pre-plumb to these dimensions.

UNLESS OTHERWISE SPECIFIED: DIMENSIONS ARE IN: INCHES (mm) TOLERANCES ARE: FRACTIONS DECIMALS ANGLES ± 1/2" .XX ± .01 ± 1/4° .XXX ± .005 .XXXX ± .0005		ENGINEERED FOR: STANDARD		LAKOS. CLAUDE LAVAL CORP. FRESNO, CALIFORNIA 93727 WWW.LAKOS.COM	
DO NOT SCALE DRAWING		APPROVALS	DATE	TITLE	
MATERIAL PER LAKOS SPEC		DRAWN ADJ	6/24/10	TCX-0600-ABV, TC SYSTEM SWEEPER HTX-0450, 3/60/460	
FINISH AS ASSEMBLED		ENGR ADJ	6/24/10	SIZE C	MODEL NO.
		MFG -	-	DWG NO.	131754-TCX
		WORK ORDER	QTY.	EST. WT.	1462 lb
				SHEET	1 OF 1

DWG NO.

131754-TCX

SH

REV. D

A