

EXCEPT AS OTHERWISE PROVIDED BY CONTRACT, THIS DRAWING AND SPECIFICATIONS SHALL NOT BE REPRODUCED, COPIED OR USED AS THE BASIS FOR MANUFACTURE OR SALE OF MATTER DEPICTED HEREIN WITHOUT THE EXPRESSED WRITTEN PERMISSION OF THE LAKOS CORPORATION, OR ITS ASSIGNEES.

THIS DRAWING HAS BEEN GENERATED AND IS MAINTAINED BY A CAD SYSTEM. CHANGES SHALL ONLY BE INCORPORATED AS DIRECTED BY AN APPROVED ENGINEERING CHANGE ORDER (ECO). PAPER COPIES ARE UNCONTROLLED.

REVISION HISTORY				
ZONE	REV	DESCRIPTION	DATE	APPROVED
	A	RELEASED FOR SUBMITTAL	6/15/2006	RGM
	B	UPDATED ELECTRICAL BOX FOR ABV	9/27/2007	ADJ
	C	CORRECTED MIN INLET SIZE FROM 8" TO 6", UPDATED SHEET TEMPLATE	3/20/2019	DGB

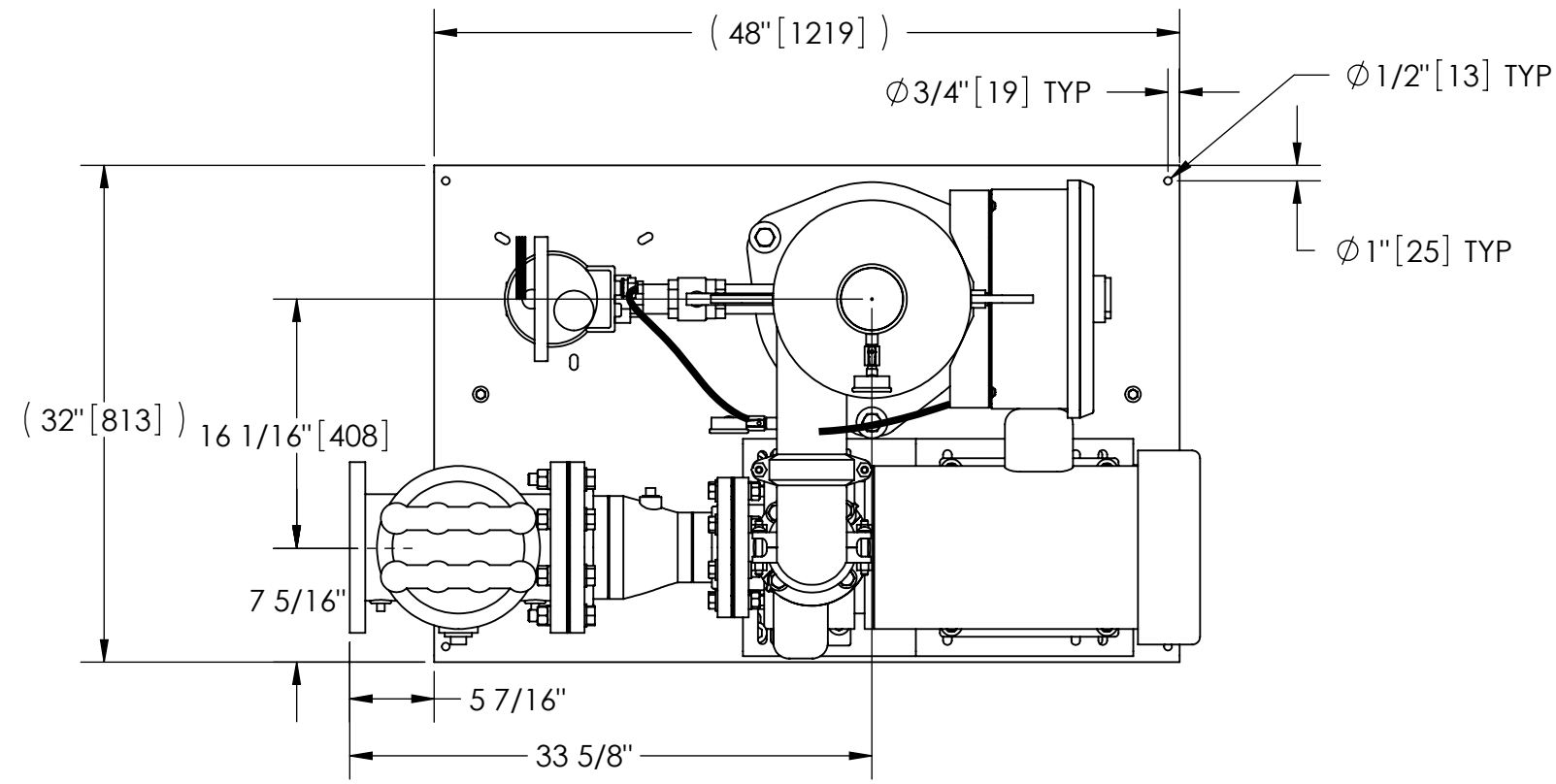

TOP VIEW

NOTES:

1. INLET IS 6" PIPE (125# ANSI FLANGED).
2. OUTLET IS 4" PIPE (GROOVED).
3. PURGE OUTLET IS 1-1/2" PIPE.
4. MAXIMUM PRESSURE: 150 psi (10.3 bar).
5. MAXIMUM TEMPERATURE: 100°F (37.8°C).
6. SPECIFIED FLOWRATE OF 525 gpm (119 m³/hr).
7. FINISH: AS ASSEMBLED.
8. POWER REQUIREMENT: 460V, 3PH, 60Hz.
9. NEMA 4X MOTOR STARTER ENCLOSURE WITH SAFETY DISCONNECT AND H.O.A. SWITCH.
10. APPROXIMATE DRY WEIGHT: 1199 lbs (544 kg).
11. INLET/OUTLET VALVE KIT, MODEL TCV-0525 RECOMMENDED.
12. MINIMUM PIPE FROM TOWER BASIN TO TC SYSTEM IS 6" PIPE.
13. FLOODED SUCTION REQUIRED.

COMPONENT LIST:

- ① ELECTRICAL CONTROL BOX 460V 60Hz W/120V TRANSFORMER.
- ② SEPARATOR: HTH-0285-TC.
- ③ PUMP: 20 HP CENTRIFUGAL, 3500 rpm, 460V, 60Hz.
- ④ INLET/OUTLET PRESSURE GAUGES: 0-100 psi, GLYCERIN-FILLED.
- ⑤ PURGE EQUIPMENT: ABV-15-120V.
- ⑥ BASKET STRAINER.

SUBMITTAL DRAWING

This drawing is submitted for spatial consideration only. Do not pre-plumb to these dimensions.

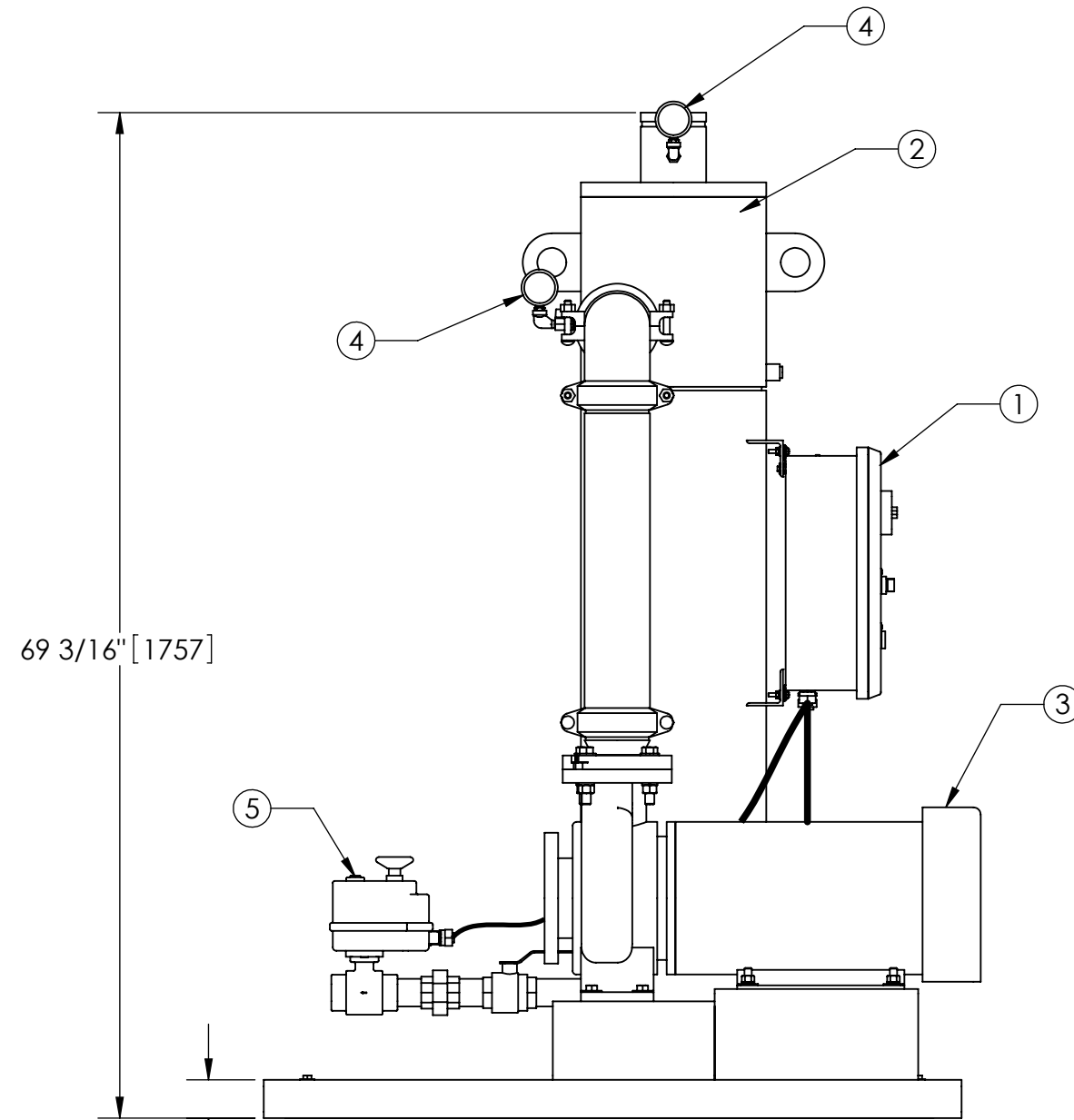

FRONT VIEW W/O STRAINER

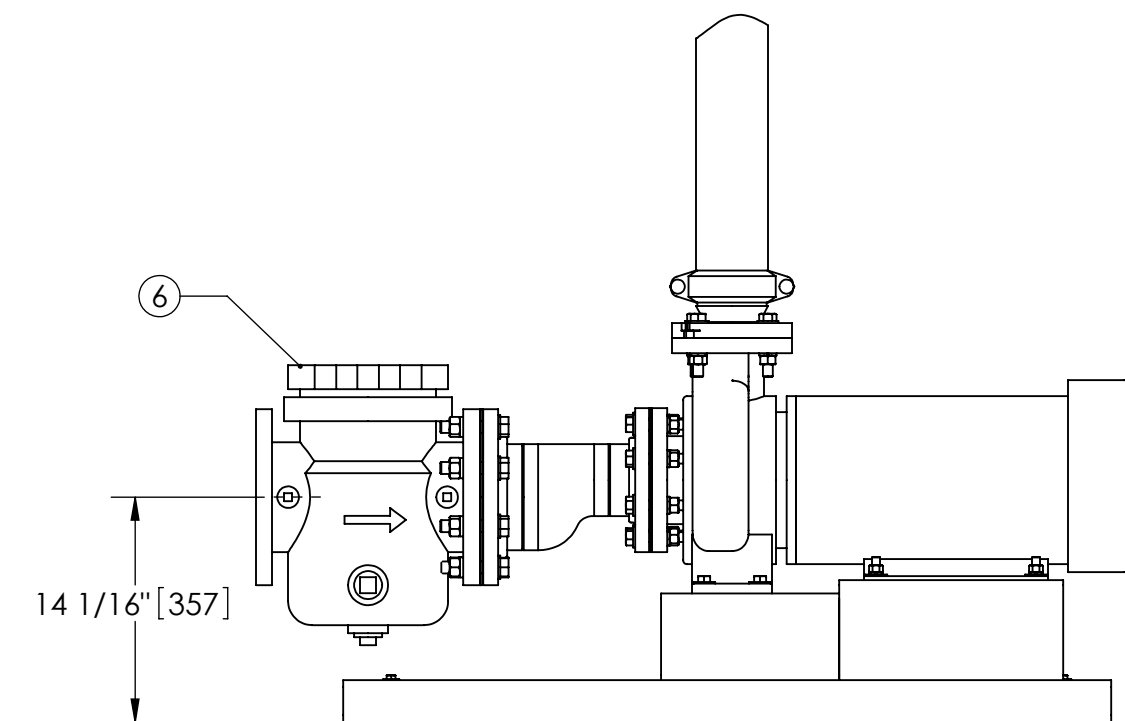

FRONT VIEW PUMP & STRAINER

UNLESS OTHERWISE SPECIFIED: DIMENSIONS ARE IN: INCHES [mm] TOLERANCES ARE: FRACTIONS DECIMALS ANGLES ± 1/4" .XX ± .01 ± 1/4° .XXX ± .005 .XXXX ± .0005		ENGINEERED FOR: STANDARD			
DO NOT SCALE DRAWING	APPROVALS	DATE	TITLE		
MATERIAL PER LAKOS SPEC	DRAWN ADJ/DLW	1/4/05	TCI-0525-ABV, TC SYSTEM, SWEEPER HTH-0285, 460V 60HZ STD		
FINISH AS ASSEMBLED	ENGR HSK	9/13/05	SIZE C	MODEL NO.	DWG NO. 122725
	WORK ORDER	QTY.	SCALE 1:12	EST. WT. 1199 lb	SHEET 1 OF 1

DWG NO. 122725
SHEET 1
REV. C