

EXCEPT AS OTHERWISE PROVIDED BY CONTRACT, THIS DRAWING AND SPECIFICATIONS SHALL NOT BE REPRODUCED, COPIED OR USED AS THE BASIS FOR MANUFACTURE OR SALE OF MATTER DEPICTED HEREIN WITHOUT THE EXPRESSED WRITTEN PERMISSION OF THE LAKOS CORPORATION, OR ITS ASSIGNEES.

THIS DRAWING HAS BEEN GENERATED AND IS MAINTAINED BY A CAD SYSTEM. CHANGES SHALL ONLY BE INCORPORATED AS DIRECTED BY AN APPROVED ENGINEERING CHANGE ORDER (ECO). PAPER COPIES ARE UNCONTROLLED.

REVISIONS				
ZONE	REV.	DESCRIPTION	DATE	APPROVED
-	A	MFG UPDATE	10/30/2006	DLW
-	D	REVISED MOTOR MOUNT & NEW STY STRAINER	7/12/2012	SUB
-	E	CHANGE PUMP AND ADD NEW PUMP MOUNTS	2/11/13	TRR
-	F	UPDATE CURRENT STD	10/24/16	SUB
-	G	CHANGE TO XYLEM PUMP	7/17/19	TPF

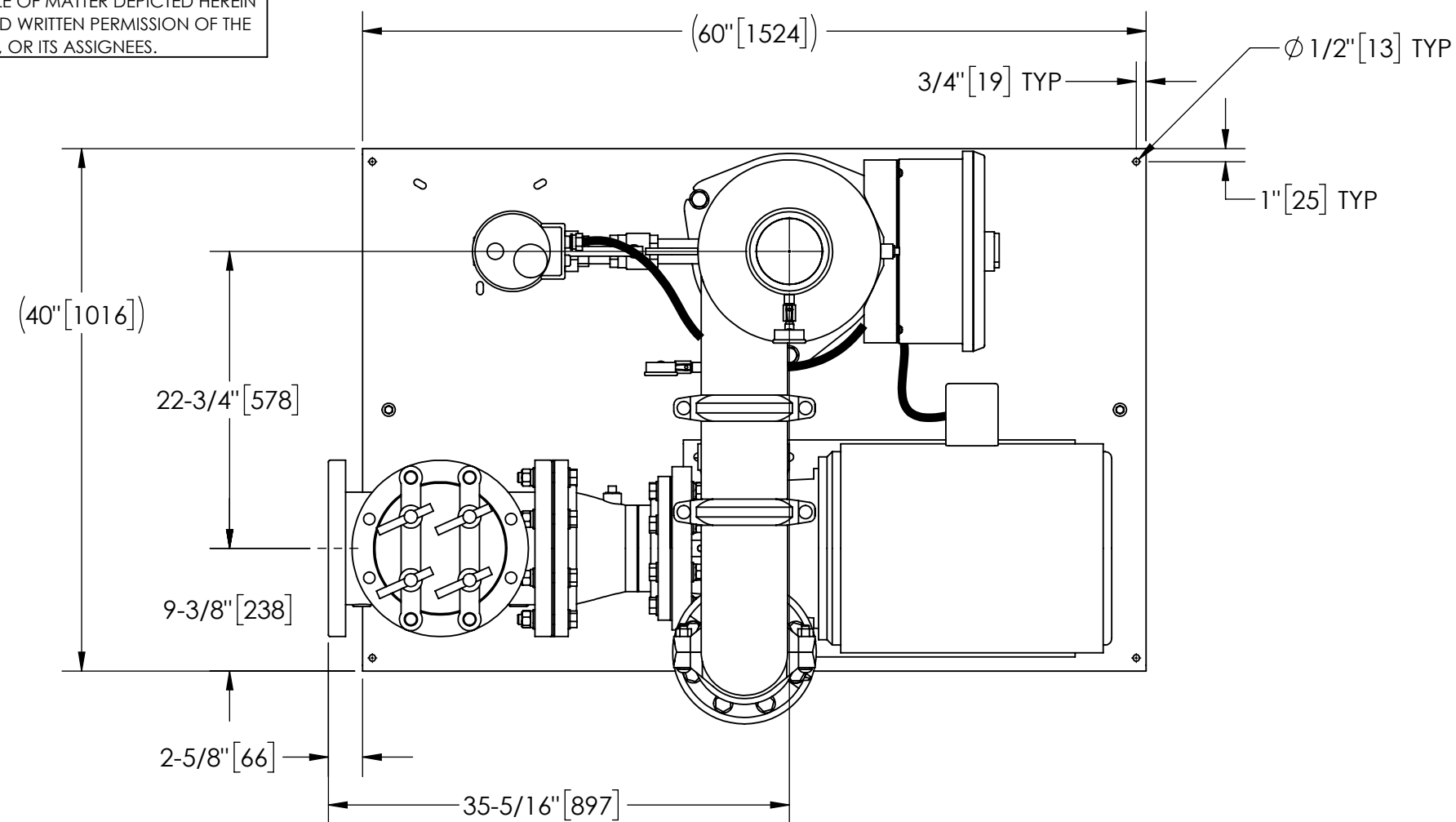

TOP VIEW

NOTES:

1. INLET IS 8" PIPE (125# ANSI FLANGED).
2. OUTLET IS 6" PIPE (GROOVED).
3. PURGE OUTLET IS 1-1/2" PIPE.
4. MAXIMUM PRESSURE: 150 psi (10.3 bar).
5. MAXIMUM TEMPERATURE: 100°F (37.8°C).
6. SPECIFIED FLOWRATE OF 825 gpm (187 m³/hr).
7. FINISH: AS ASSEMBLED.
8. POWER REQUIREMENT: 460V, 3PH, 60Hz.
9. NEMA 4X MOTOR STARTER ENCLOSURE WITH SAFETY DISCONNECT AND H.O.A. SWITCH.
10. APPROXIMATE DRY WEIGHT: 2037 lbs (924 kg).
11. INLET/OUTLET VALVE KIT, MODEL TCV-0825 RECOMMENDED.
12. MINIMUM PIPE FROM TOWER BASIN TO TC SYSTEM IS 8" PIPE.
13. FLOODED SUCTION REQUIRED.

COMPONENT LIST:

- ① ELECTRICAL CONTROL BOX 460V 60Hz W/120V TRANSFORMER.
- ② SEPARATOR: HTH-0450-TC.
- ③ PUMP: 30 HP CENTRIFUGAL, 1800 rpm, 460V, 60Hz.
- ④ INLET/OUTLET PRESSURE GAUGES: 0-160 psi, GLYCERIN-FILLED.
- ⑤ PURGE EQUIPMENT: ABV-15-120V.
- ⑥ BASKET STRAINER.

SUBMITTAL DRAWING

This drawing is submitted for spatial consideration only. Do not pre-plumb to these dimensions.

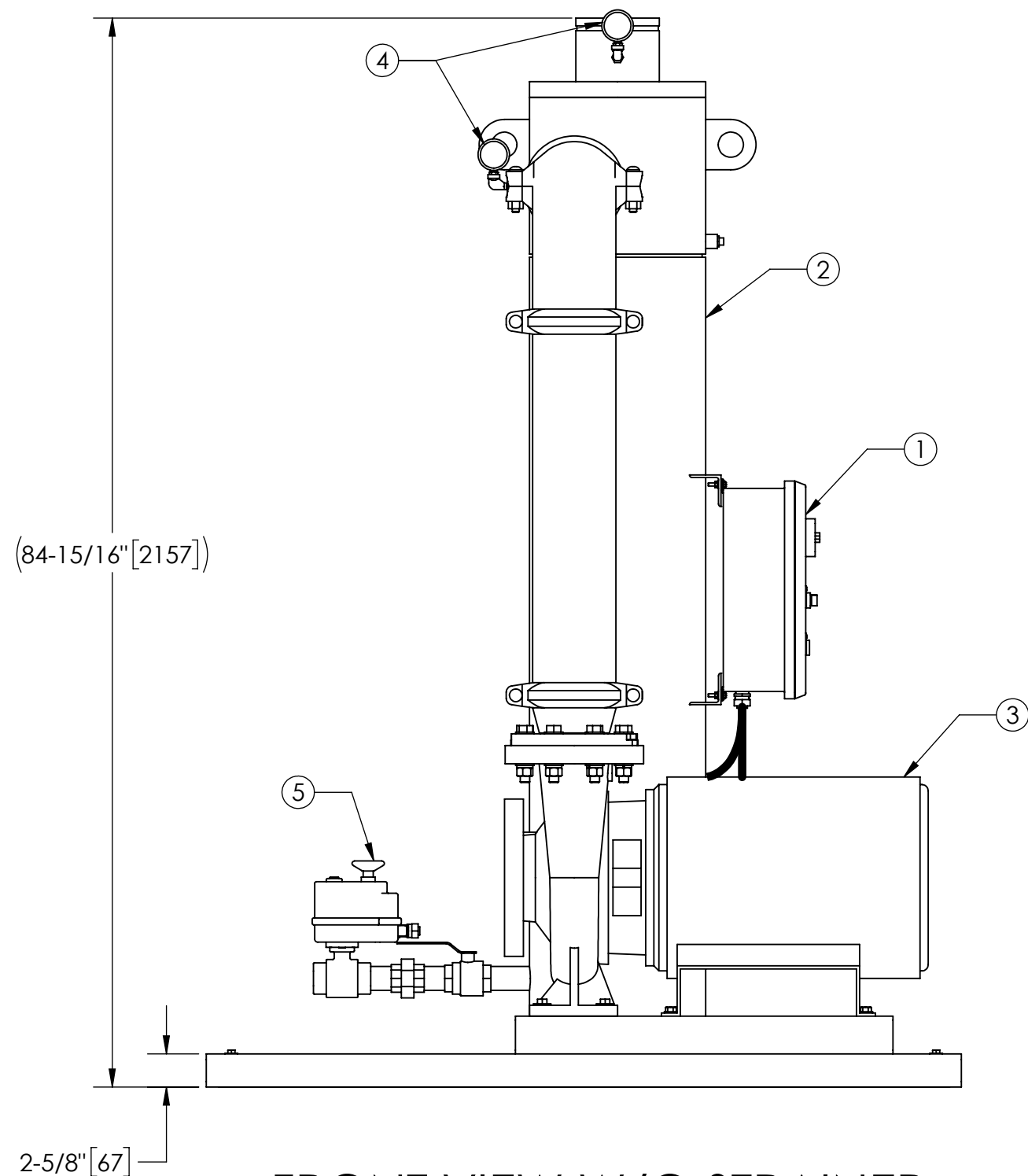

FRONT VIEW W/O STRAINER

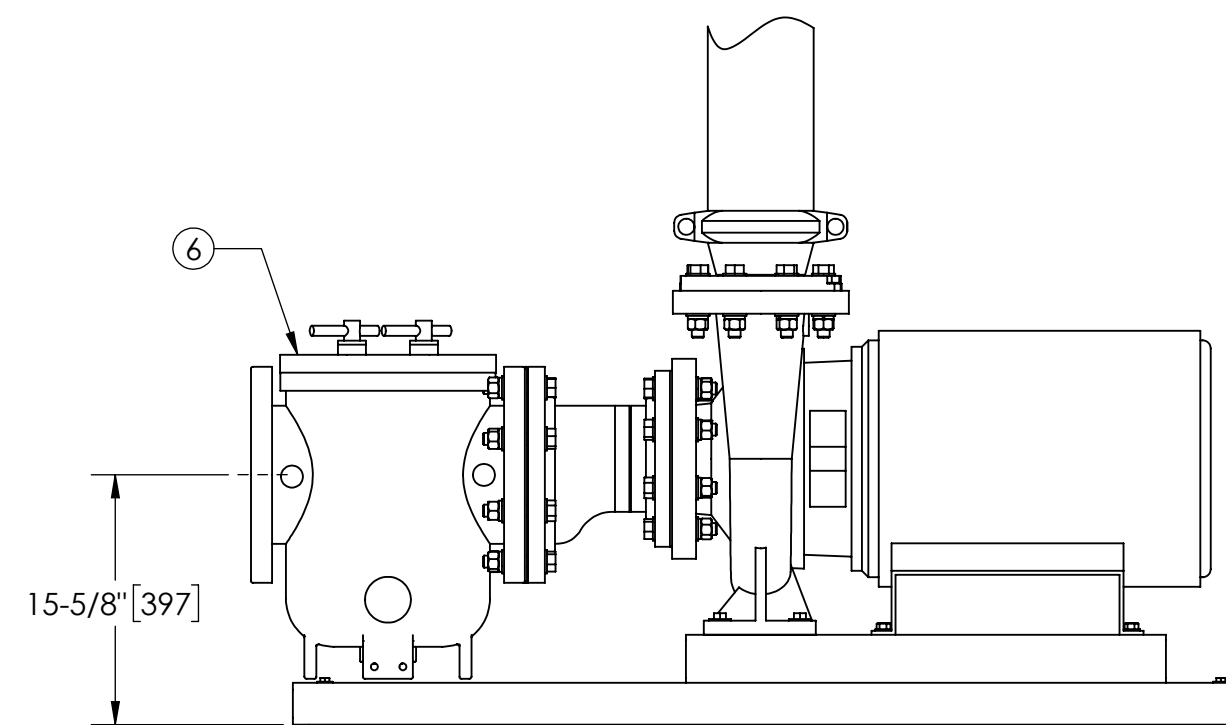

FRONT VIEW PUMP & STRAINER

UNLESS OTHERWISE SPECIFIED: DIMENSIONS ARE IN: INCHES (mm) TOLERANCES ARE: FRACTIONS DECIMALS ANGLES $\pm 1"$ .XX $\pm .01$ $\pm 1/4^\circ$ .XXX $\pm .005$ .XXXX $\pm .0005$	ENGINEERED FOR:		FRESNO, CALIFORNIA WWW.LAKOS.COM		
	STANDARD				
	DO NOT SCALE DRAWING	APPROVALS	DATE	TITLE TCI-0825-ABV, TC SYSTEM, SWEEPER HTH-0450, 460V 60HZ STD	
	MATERIAL	DRAWN	ENGR		
FINISH	REVIEW	WORK ORDER			
PER LAKOS SPEC	DLW	DLW	SIZE C SCALE 1:12	MODEL NO. DWG NO. 122726 EST. WT. 2037 lb	REV. G SHEET 1 OF 1

DWG NO. 122726 SH 1 REV. G