

EXCEPT AS OTHERWISE PROVIDED BY CONTRACT, THIS DRAWING AND SPECIFICATIONS SHALL NOT BE REPRODUCED, COPIED OR USED AS THE BASIS FOR MANUFACTURE OR SALE OF MATTER DEPICTED HEREIN WITHOUT THE EXPRESSED WRITTEN PERMISSION OF THE CLAUDE LAVAL CORPORATION, OR ITS ASSIGNEES.

THIS DRAWING HAS BEEN GENERATED AND IS MAINTAINED BY A CAD SYSTEM. CHANGES SHALL ONLY BE INCORPORATED AS DIRECTED BY AN APPROVED ENGINEERING CHANGE ORDER (ECO). PAPER COPIES ARE UNCONTROLLED.

REVISIONS				
ZONE	REV.	DESCRIPTION	DATE	APPROVED
-	A	MFG UPDATE	6/16/2006	RGM
-	B	LOWERED INLET/OUTLET	8/27/2007	DLW
-	C	REVISED MOTOR MOUNT & NEW STY STRAINER	7/12/2012	SUB
-	D	REPLACE PUMP AND SKID	1/15/13	TRR

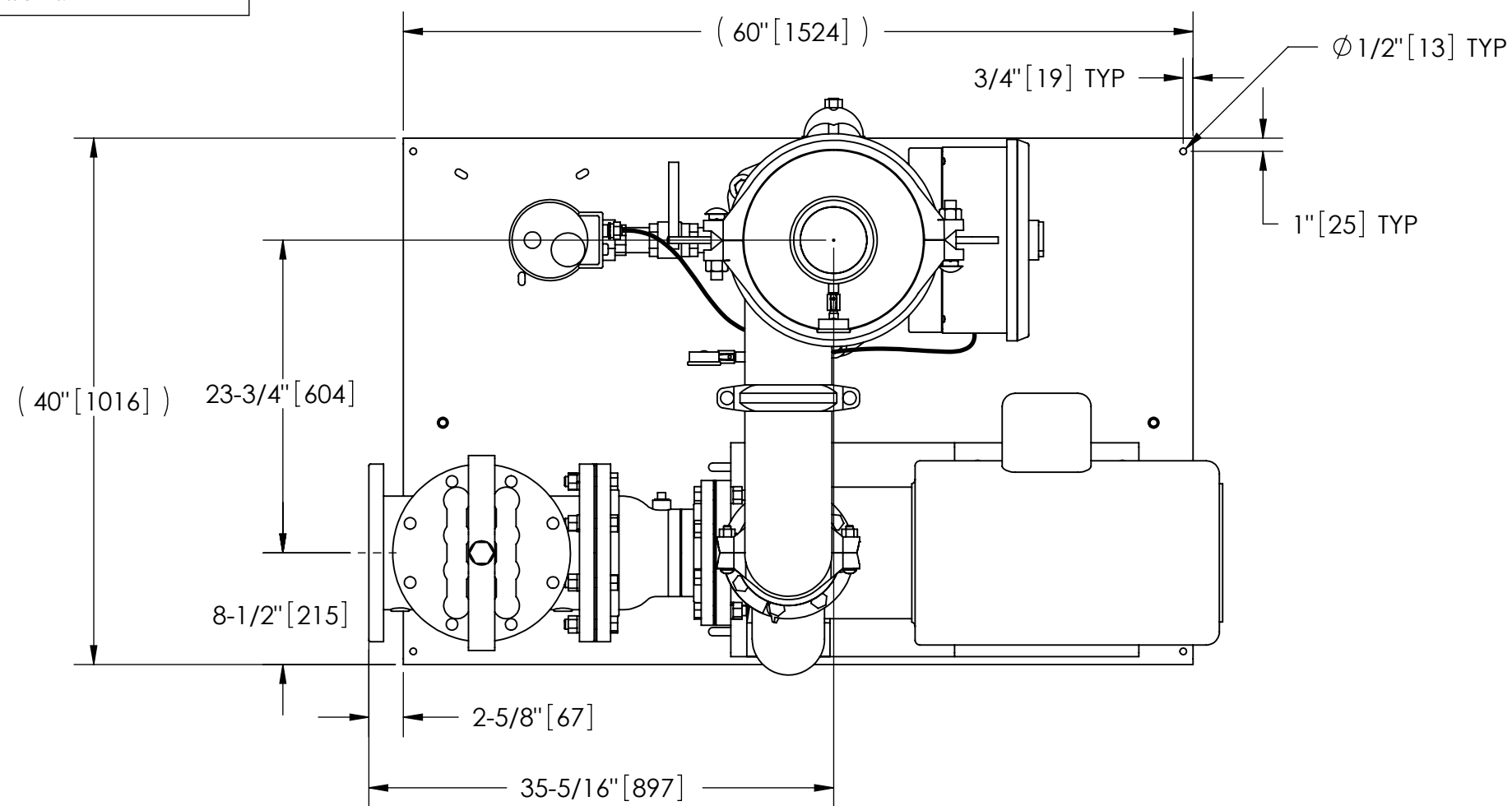

TOP VIEW

NOTES:

1. INLET IS 8" PIPE (125# ANSI FLANGED).
2. OUTLET IS 6" PIPE (GROOVED).
3. PURGE OUTLET IS 1-1/2" PIPE.
4. MAXIMUM PRESSURE: 150 psi (10.3 bar).
5. MAXIMUM TEMPERATURE: 100°F (37.8°C).
6. SPECIFIED FLOWRATE OF 825 gpm (187 m³/hr).
7. FINISH: AS ASSEMBLED.
8. POWER REQUIREMENT: 460V, 3PH, 60Hz.
9. NEMA 4X MOTOR STARTER ENCLOSURE WITH SAFETY DISCONNECT AND H.O.A. SWITCH.
10. APPROXIMATE DRY WEIGHT: 2528 lbs (1147 kg).
11. INLET/OUTLET VALVE KIT, MODEL TCV-0825 RECOMMENDED.
12. MINIMUM PIPE FROM TOWER BASIN TO TC SYSTEM IS 8" PIPE.
13. FLOODED SUCTION REQUIRED.

COMPONENT LIST:

- ① ELECTRICAL CONTROL BOX 460V 60Hz W/120V TRANSFORMER.
- ② SEPARATOR: HTX-0450-TC.
- ③ PUMP: 30 HP CENTRIFUGAL, 1800 rpm, 460V, 60Hz.
- ④ INLET/OUTLET PRESSURE GAUGES: 0-100 psi, GLYCERIN-FILLED.
- ⑤ PURGE EQUIPMENT: ABV-15-120V.
- ⑥ BASKET STRAINER.

SUBMITTAL DRAWING

This drawing is submitted for spatial consideration only. Do not pre-plumb to these dimensions.

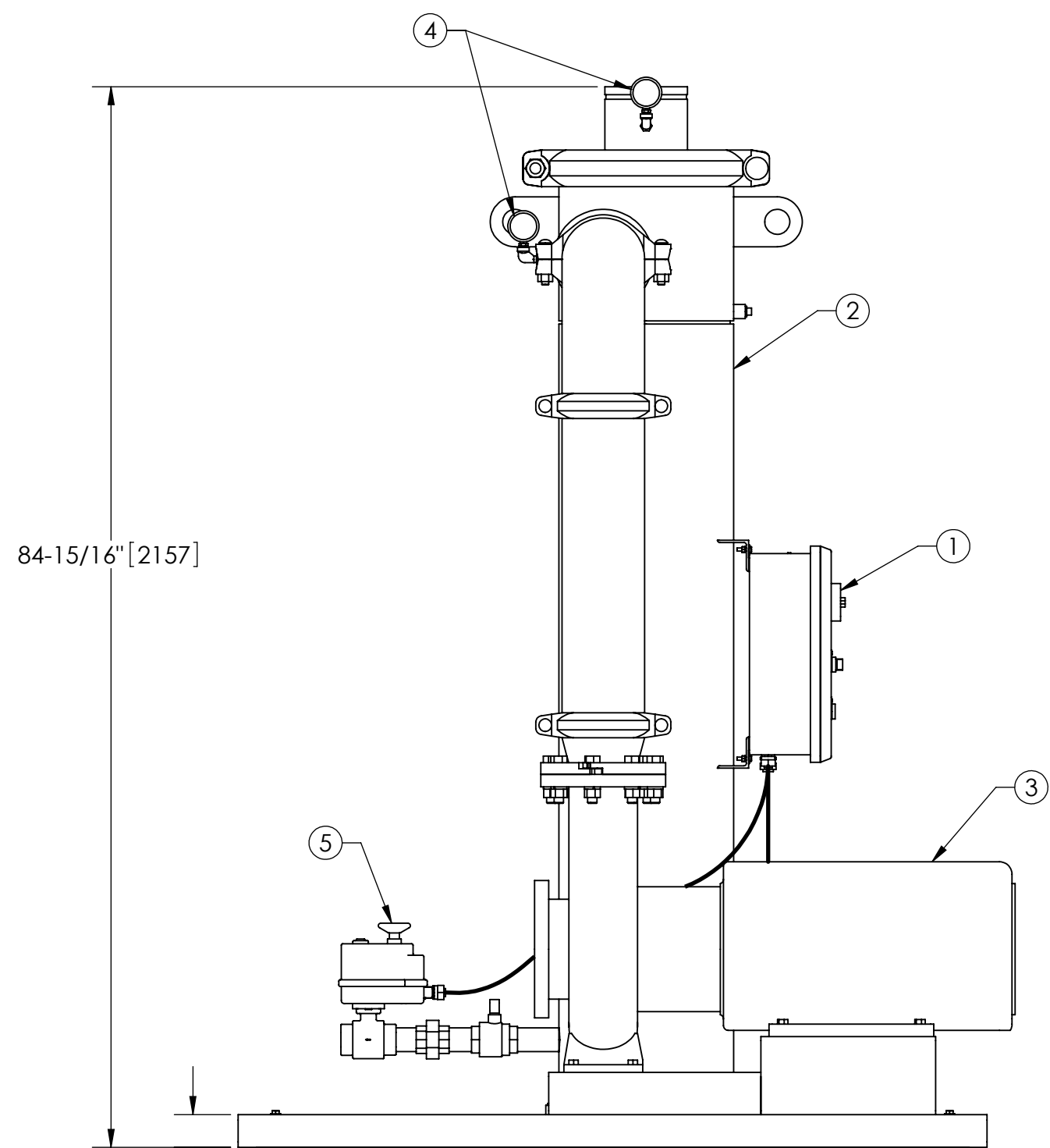

FRONT VIEW W/O STRAINER

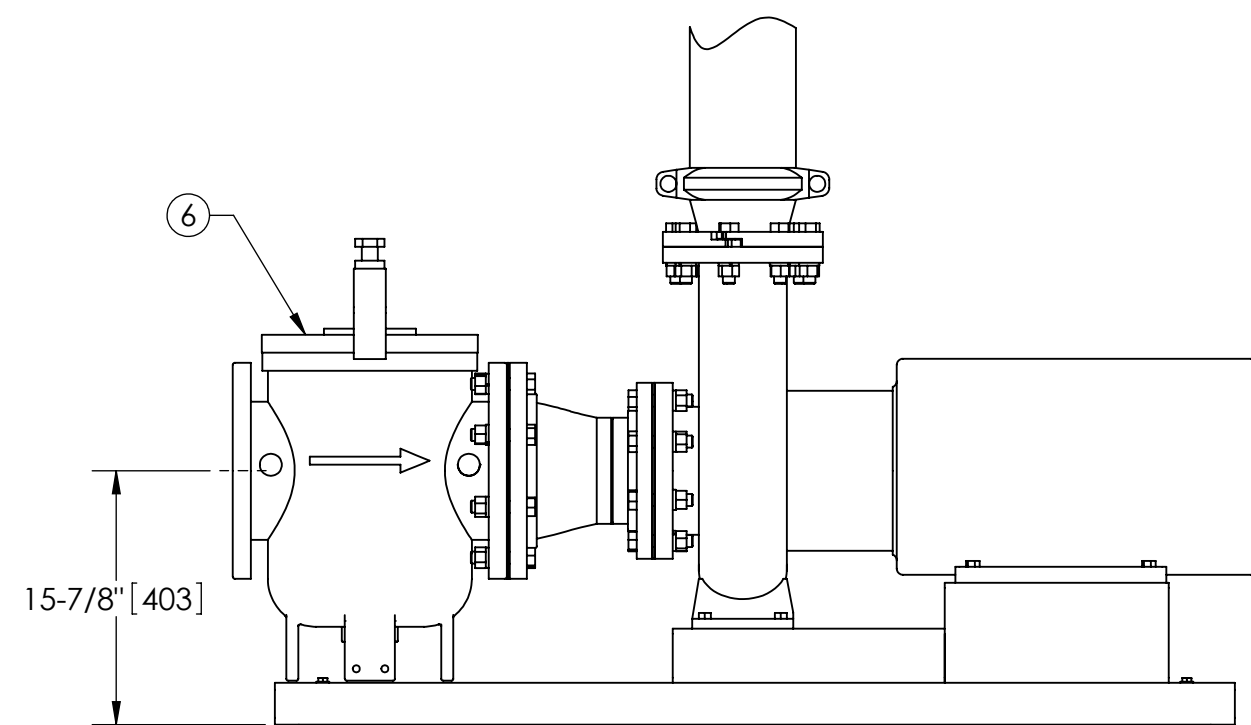

FRONT VIEW PUMP & STRAINER

UNLESS OTHERWISE SPECIFIED: DIMENSIONS ARE IN: INCHES (mm) TOLERANCES ARE: FRACTIONS .XX ± .01 DECIMALS .XXX ± .005 ANGLES ± 1/4° XXX ± .005 XXXX ± .0005	ENGINEERED FOR: STANDARD	CLAUDE LAVAL CORP. FRESNO, CALIFORNIA 93727 WWW.LAKOS.COM	LAVAL UNDERGROUND SURVEYS
	APPROVALS		
DO NOT SCALE DRAWING	DRAWN ADJ/DLW	5/5/05	TITLE TCX-0825-ABV, TC SYSTEM, SWEEPER HTX-0450, 460V 60HZ DELUXE
MATERIAL PER LAKOS SPEC	ENGR DLW	8/27/07	SIZE C
FINISH AS ASSEMBLED	MFG -	-	MODEL NO.
	WORK ORDER	QTY.	DWG NO. 122734
			EST. WT. 2528 lb
			SHEET 1 OF 1

DWG NO. 122734
SHEET 1
REV. D