

EXCEPT AS OTHERWISE PROVIDED BY CONTRACT, THIS DRAWING AND SPECIFICATIONS SHALL NOT BE REPRODUCED, COPIED OR USED AS THE BASIS FOR MANUFACTURE OR SALE OF MATTER DEPICTED HEREIN WITHOUT THE EXPRESSED WRITTEN PERMISSION OF THE LAKOS CORPORATION, OR ITS ASSIGNEES.

THIS DRAWING HAS BEEN GENERATED AND IS MAINTAINED BY A CAD SYSTEM. CHANGES SHALL ONLY BE INCORPORATED AS DIRECTED BY AN APPROVED ENGINEERING CHANGE ORDER (ECO). PAPER COPIES ARE UNCONTROLLED.

| REVISIONS |      |                        |           |          |
|-----------|------|------------------------|-----------|----------|
| ZONE      | REV. | DESCRIPTION            | DATE      | APPROVED |
|           | 01   | RELEASED FOR SUBMITTAL | 9/14/2022 | AAM      |

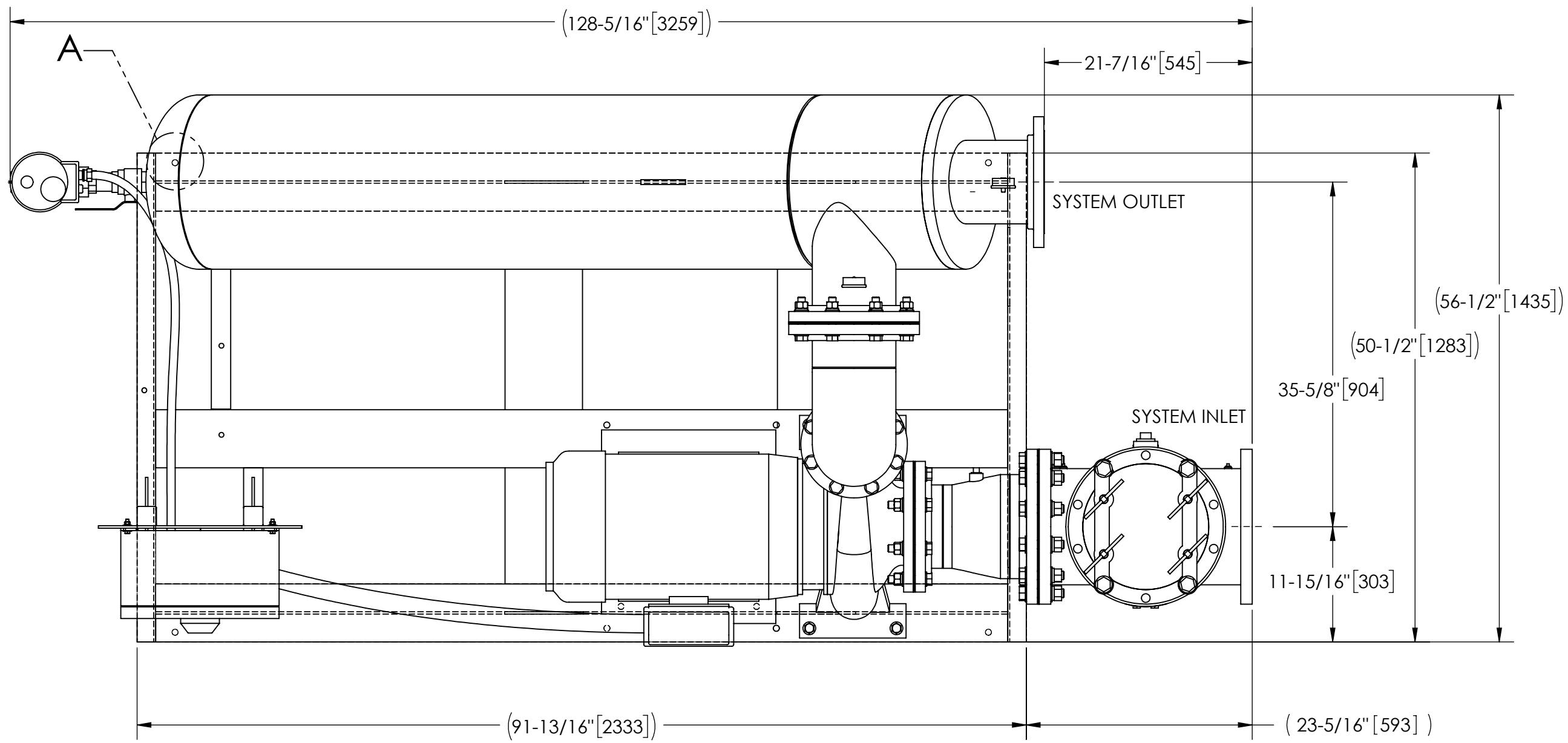

**TOP VIEW**

**NOTES:**

1. INLET IS 10" PIPE (125# ANSI FLANGED).
2. OUTLET IS 8" PIPE (150# ANSI FLANGED).
3. PURGE OUTLET IS 1-1/2" PIPE.
4. MAXIMUM PRESSURE: 150 psi (10.3 bar).
5. MAXIMUM FLUID TEMPERATURE: 100°F (37.8°C).
6. MAXIMUM AMBIENT TEMPERATURE: 100°F (37.8°C).
7. SPECIFIED FLOWRATE OF 1670 gpm (379 m³/hr).
8. FINISH: AS ASSEMBLED.
9. POWER REQUIREMENT: 3/60/460V.
10. APPROXIMATE DRY WEIGHT: 3078 lbs (1396 kg).
11. MINIMUM PIPE FROM TOWER BASIN TO TC SYSTEM IS 12" PIPE.
12. FLOODED SUCTION REQUIRED.

**COMPONENT LIST:**

- ① ELECTRICAL CONTROL BOX 3/60/460V, W/120V TRANSFORMER.
- ② SEPARATOR: HTH-0810-L/FLG.
- ③ PUMP: 50 HP, 1800 RPM, END SUCTION CENTRIFUGAL, 3/60/460V.
- ④ INLET/OUTLET PRESSURE GAUGES: 0-160 psi, GLYCERIN-FILLED.
- ⑤ PURGE EQUIPMENT: ABV-15-120V.
- ⑥ SKID: CARBON STEEL, LAKOS BLACK.
- ⑦ BASKET STRAINER 10"

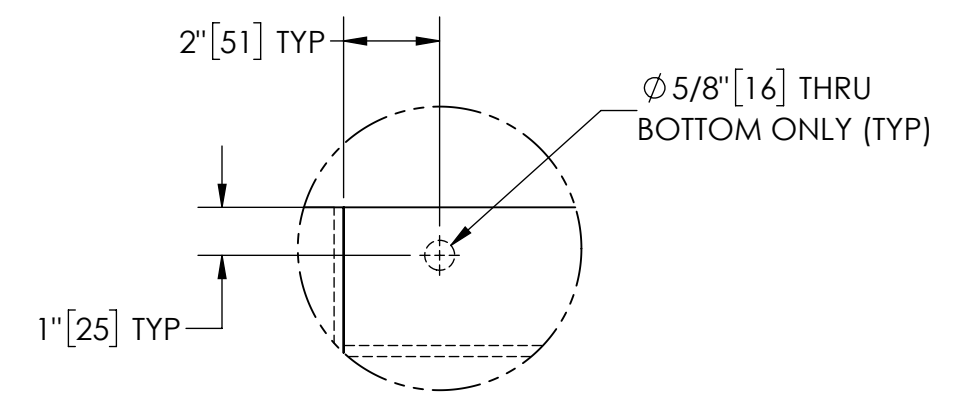

**DETAIL A**  
SCALE 1:4

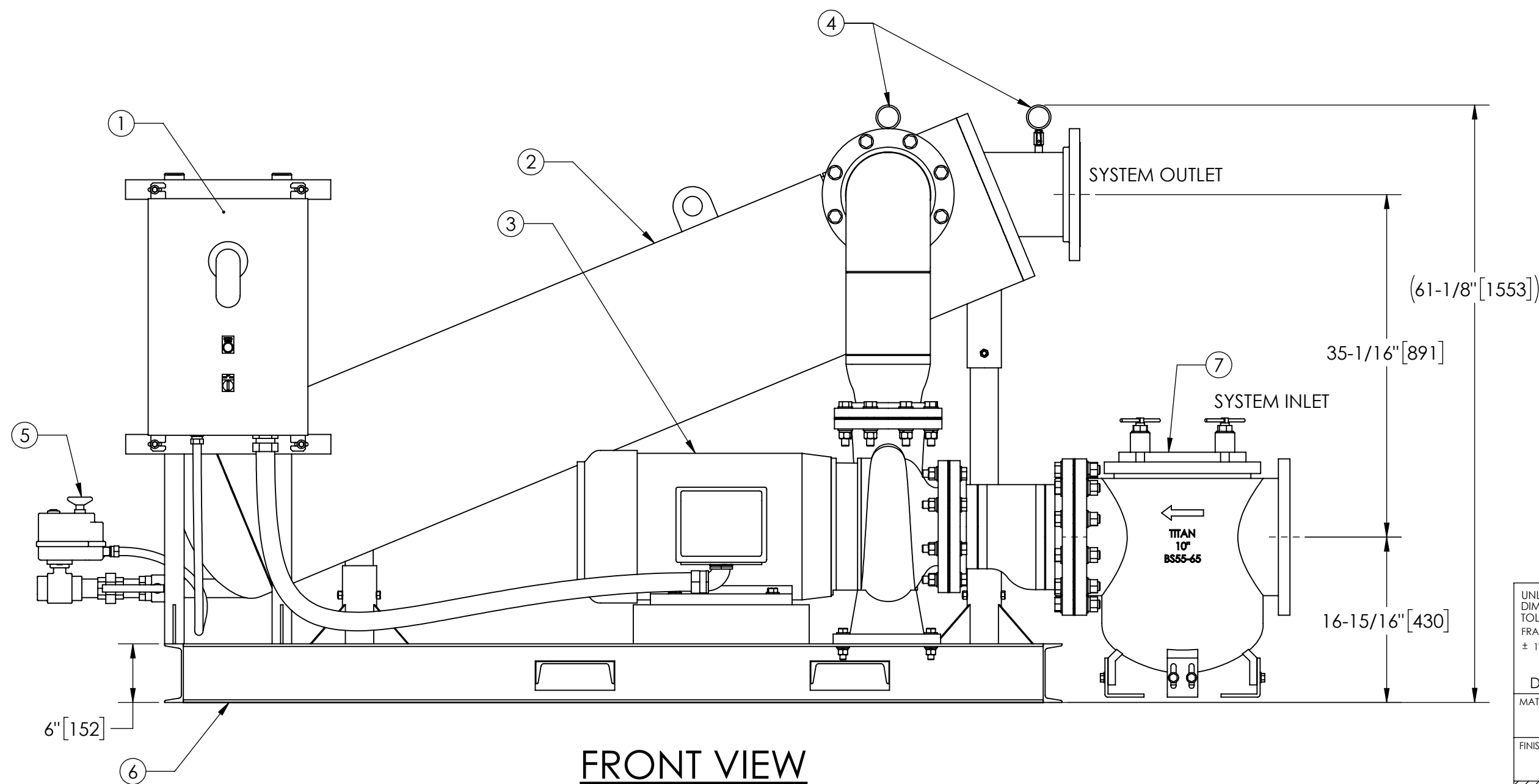

**FRONT VIEW**

**SUBMITTAL DRAWING**

This drawing is submitted for spatial consideration only. Do not pre-plumb to these dimensions.

|  |  |                                    |         |   |                    |
|--|--|------------------------------------|---------|---|--------------------|
| UNLESS OTHERWISE SPECIFIED:<br>DIMENSIONS ARE IN: INCHES (mm)<br>TOLERANCES ARE:<br>FRACTIONS DECIMALS ANGLES<br>± 1" .XX ± .01 ± 1/4"<br>XXX ± .005<br>XXXX ± .0005 |  | ENGINEERED FOR:<br><b>STANDARD</b> |         |  |                    |
| DO NOT SCALE DRAWING   |  | APPROVALS                          | DATE    | TITLE   |                    |
| MATERIAL PER LAKOS SPEC  |  | DRAWN AAM                          | 9/12/22 | TCI-1670-ABV/L, TC SYSTEM,<br>SWEEPER HTH-0810-L/FLG, 3/60/460V                       |                    |
| FINISH AS ASSEMBLED  |  | ENGR -                             | -       | SIZE C  | MODEL NO.          |
|  |  | REVIEW -                           | -       | SCALE 1:12  | DWG NO. 131546-460 |
|  |  | WORK ORDER                         | QTY.    | EST. WT. 3078 lb  | SHEET 1 OF 1       |

DWG. NO. 131546-460 SHEET 1 REV. 01