

EXCEPT AS OTHERWISE PROVIDED BY CONTRACT, THIS DRAWING AND SPECIFICATIONS SHALL NOT BE REPRODUCED, COPIED OR USED AS THE BASIS FOR MANUFACTURE OR SALE OF MATTER DEPICTED HEREIN WITHOUT THE EXPRESSED WRITTEN PERMISSION OF THE CLAUDE LAVAL CORPORATION, OR ITS ASSIGNEES.

THIS DRAWING HAS BEEN GENERATED AND IS MAINTAINED BY A CAD SYSTEM. CHANGES SHALL ONLY BE INCORPORATED AS DIRECTED BY AN APPROVED ENGINEERING CHANGE ORDER (ECO). PAPER COPIES ARE UNCONTROLLED.

REVISION HISTORY				
ZONE	REV	DESCRIPTION	DATE	APPROVED
-	A	LOWERED INLET/OUTLET	8/27/2007	DLW
-	B	CHANGE PUMP AND PUMP MOUNTS	2/21/13	TRR

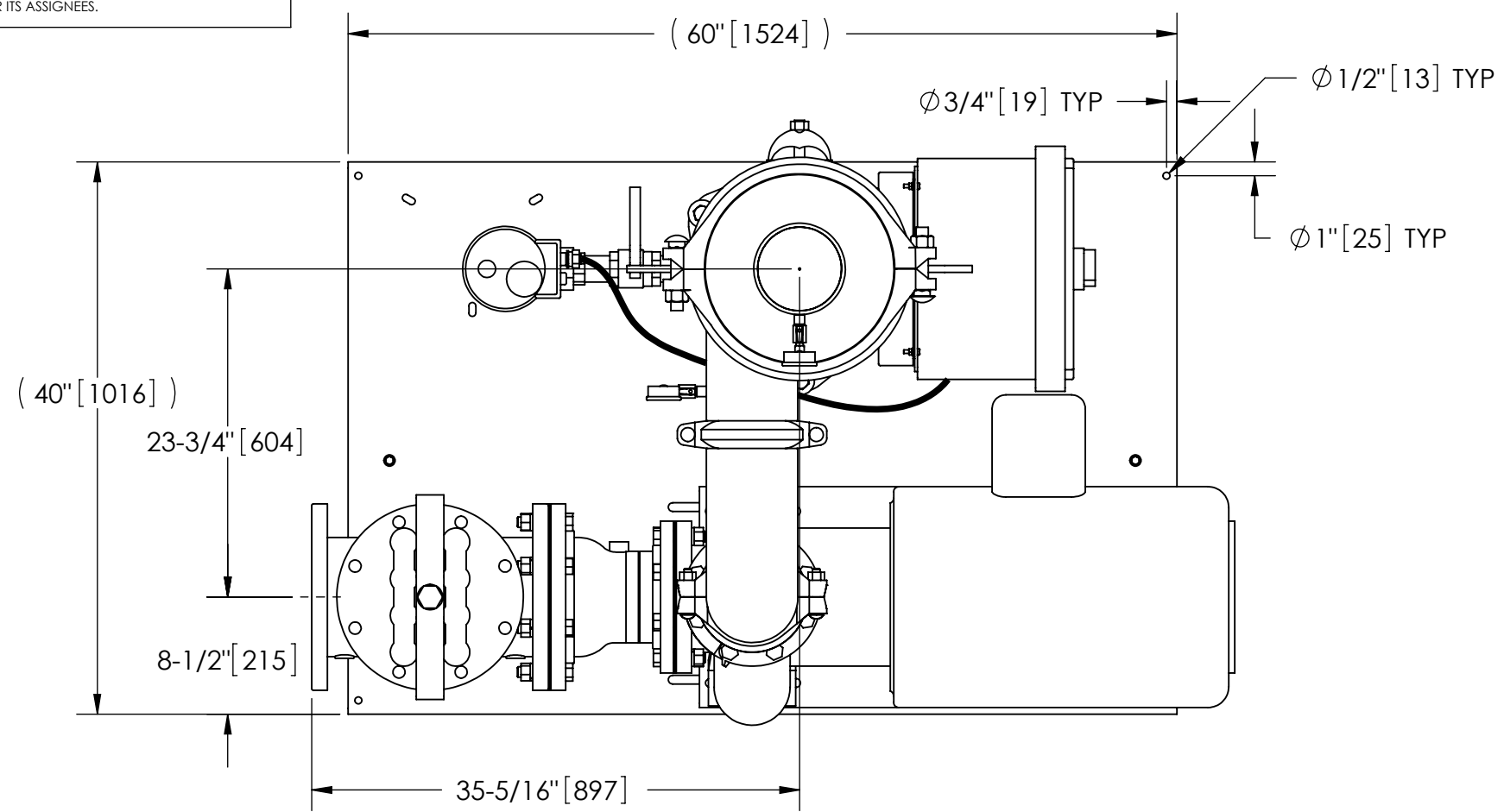

TOP VIEW

NOTES:

1. INLET IS 8" PIPE (125# ANSI FLANGED).
2. OUTLET IS 6" PIPE (GROOVED).
3. PURGE OUTLET IS 1-1/2" PIPE.
4. MAXIMUM PRESSURE: 150 psi (10.3 bar).
5. MAXIMUM TEMPERATURE: 100°F (37.8°C).
6. SPECIFIED FLOWRATE OF 1100 gpm (250 m³/hr).
7. FINISH: AS ASSEMBLED.
8. POWER REQUIREMENT: 460V, 3PH, 60Hz.
9. NEMA 4X MOTOR STARTER ENCLOSURE WITH SAFETY DISCONNECT AND H.O.A. SWITCH.
10. APPROXIMATE DRY WEIGHT: 2489 lbs (1129 kg).
11. INLET/OUTLET VALVE KIT, MODEL TCV-1100 RECOMMENDED.
12. MINIMUM PIPE FROM TOWER BASIN TO TC SYSTEM IS 10" PIPE.
13. FLOODED SUCTION REQUIRED.

COMPONENT LIST:

- ① ELECTRICAL CONTROL BOX 460V 60Hz W/120V TRANSFORMER.
- ② SEPARATOR: HTX-0500-TC.
- ③ PUMP: 40 HP CENTRIFUGAL, 1800 rpm, 460V, 60Hz.
- ④ INLET/OUTLET PRESSURE GAUGES: 0-100 psi, GLYCERIN-FILLED.
- ⑤ PURGE EQUIPMENT: ABV-15-120V.
- ⑥ BASKET STRAINER.

SUBMITTAL DRAWING

This drawing is submitted for spatial consideration only. Do not pre-plumb to these dimensions.

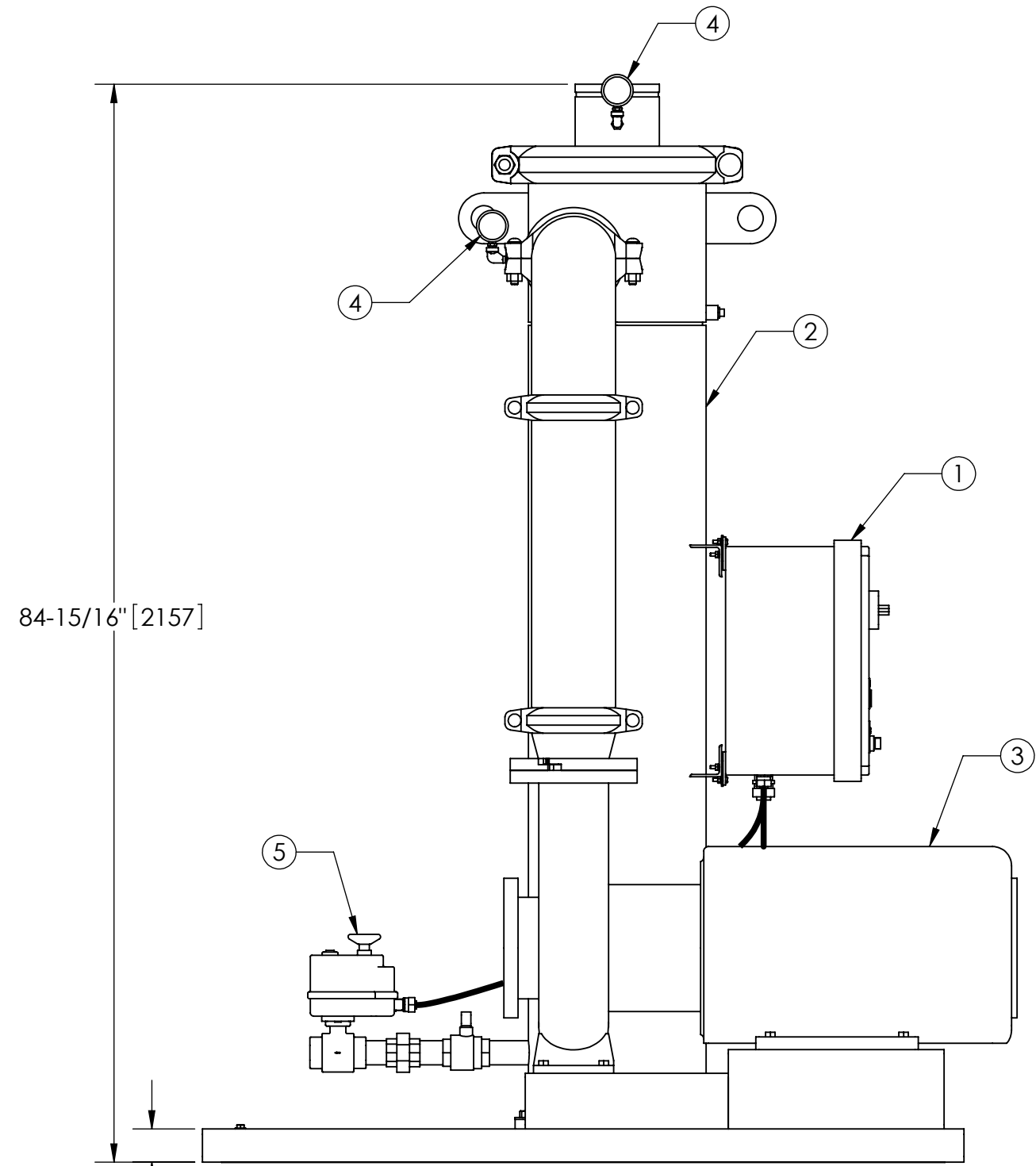

FRONT VIEW W/O STRAINER

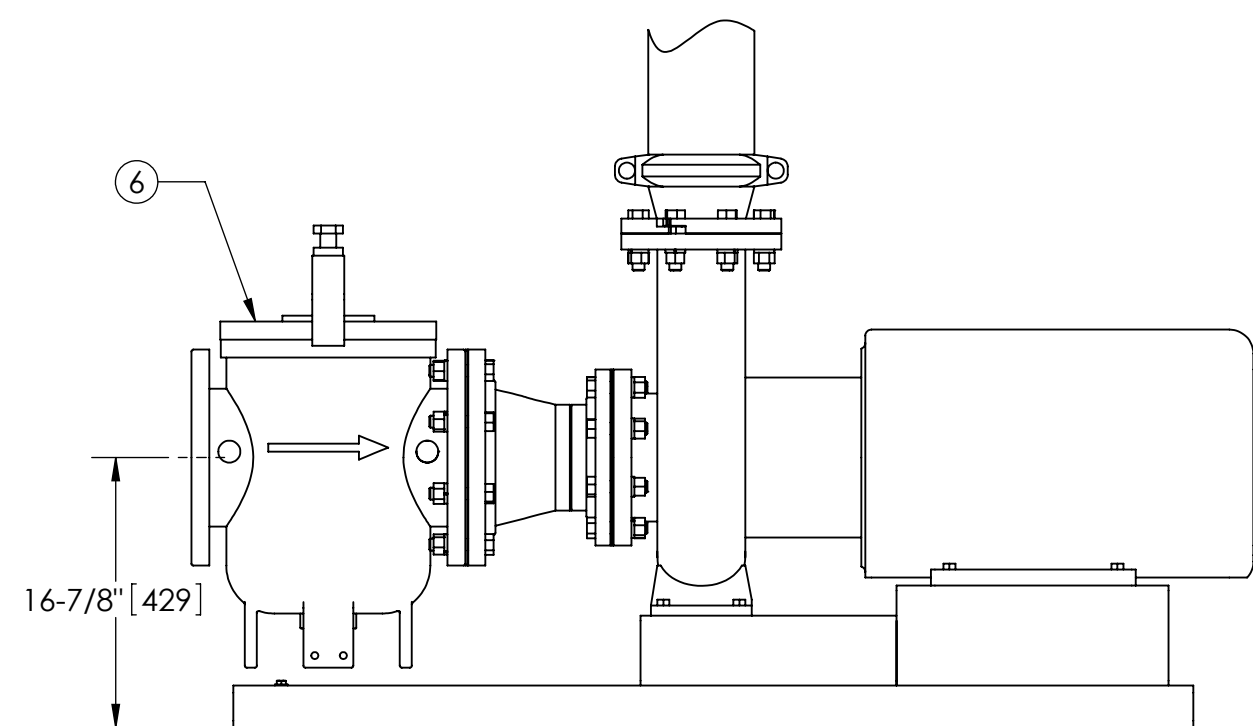

FRONT VIEW PUMP & STRAINER

UNLESS OTHERWISE SPECIFIED: DIMENSIONS ARE IN: INCHES (mm) TOLERANCES ARE: FRACTIONS .XX ± .01 ± 1/4" DECIMALS .XXX ± .005 ANGLES ± .0005	ENGINEERED FOR: <b>STANDARD</b>		CLAUDE LAVAL CORP. FRESNO, CALIFORNIA 93727 WWW.LAKOS.COM	LAVAL UNDERGROUND SURVEYS
	APPROVALS	DATE		
DO NOT SCALE DRAWING	DRAWN HSK	5/23/05	TITLE TCX-1100-ABV, TC SYSTEM, SWEEPER HTX-0500, 460V 60HZ DELUXE	
MATERIAL PER LAKOS SPEC	ENGR DLW	8/27/07	SIZE C	MODEL NO.
FINISH AS ASSEMBLED	MFG -	-	DWG NO. 122735	REV. B
	WORK ORDER	QTY.	SCALE 1:12	EST. WT. 2489 lb
			SHEET 1 OF 1	

DWG. NO. 122735 SHEET 1 REV. B