

EXCEPT AS OTHERWISE PROVIDED BY CONTRACT, THIS DRAWING AND SPECIFICATIONS SHALL NOT BE REPRODUCED, COPIED OR USED AS THE BASIS FOR MANUFACTURE OR SALE OF MATTER DEPICTED HEREIN WITHOUT THE EXPRESSED WRITTEN PERMISSION OF THE LAKOS CORPORATION, OR ITS ASSIGNEES.

THIS DRAWING HAS BEEN GENERATED AND IS MAINTAINED BY A CAD SYSTEM. CHANGES SHALL ONLY BE INCORPORATED AS DIRECTED BY AN APPROVED ENGINEERING CHANGE ORDER (ECO). PAPER COPIES ARE UNCONTROLLED.

REVISIONS				
ZONE	REV.	DESCRIPTION	DATE	APPROVED
-	A	CHG INLET/OUTLET HEIGHTS	8/29/2007	DLW
-	B	REVISED MOTOR MOUNT & NEW STY STRAINER	7/13/2012	SUB
-	C	CHANGE PUMP AND ADD NEW PUMP MOUNTS	2/11/13	TRR
	D	UPDATE CURRENT STD.	12/15/16	SUB
	E	CHANGE AMP PUMP TO XYLEM PUMP	1/21/2020	TRR

**NOTES:**

- INLET IS 8" PIPE (125# ANSI FLANGED).
- OUTLET IS 6" PIPE (GROOVED).
- PURGE OUTLET IS 1-1/2" PIPE.
- MAXIMUM PRESSURE: 150 psi (10.3 bar).
- MAXIMUM TEMPERATURE: 100°F (37.8°C).
- SPECIFIED FLOWRATE OF 1100 gpm (250 m³/hr).
- FINISH: AS ASSEMBLED.
- POWER REQUIREMENT: 460V, 3PH, 60Hz.
- NEMA 4X MOTOR STARTER ENCLOSURE WITH SAFETY DISCONNECT AND H.O.A. SWITCH.
- APPROXIMATE DRY WEIGHT: 2139 lbs (970 kg).
- INLET/OUTLET VALVE KIT, MODEL TCV-1100 RECOMMENDED.
- MINIMUM PIPE FROM TOWER BASIN TO TC SYSTEM IS 10" PIPE.
- FLOODED SUCTION REQUIRED.

**COMPONENT LIST:**

- ELECTRICAL CONTROL BOX 460V 60Hz W/120V TRANSFORMER.
- SEPARATOR: HTH-0500-TC.
- PUMP: 40 HP CENTRIFUGAL, 1800 rpm, 460V, 60Hz.
- INLET/OUTLET PRESSURE GAUGES: 0-160 psi, GLYCERIN-FILLED.
- PURGE EQUIPMENT: ABV-15-120V.
- BASKET STRAINER.

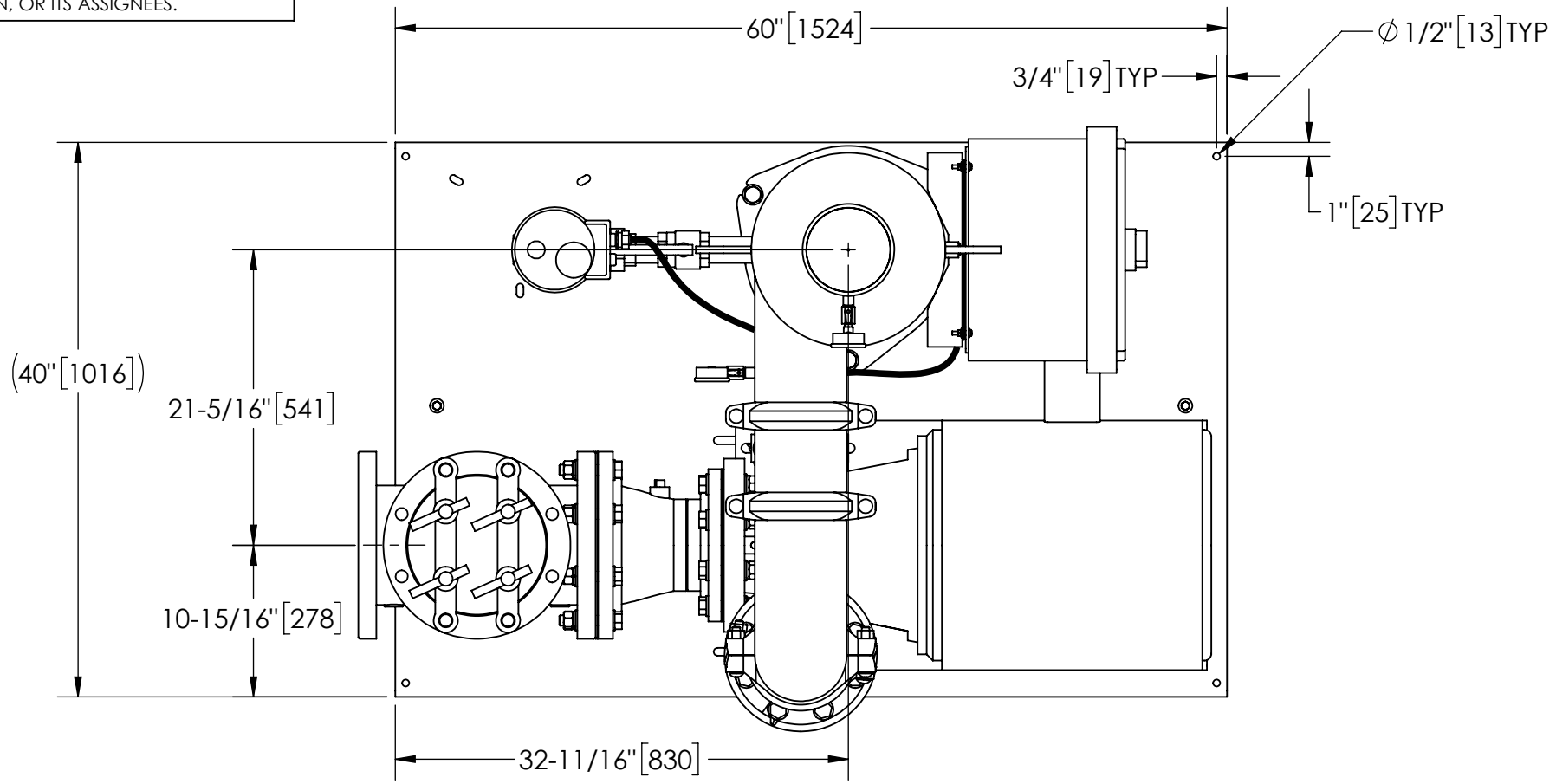

**TOP VIEW**

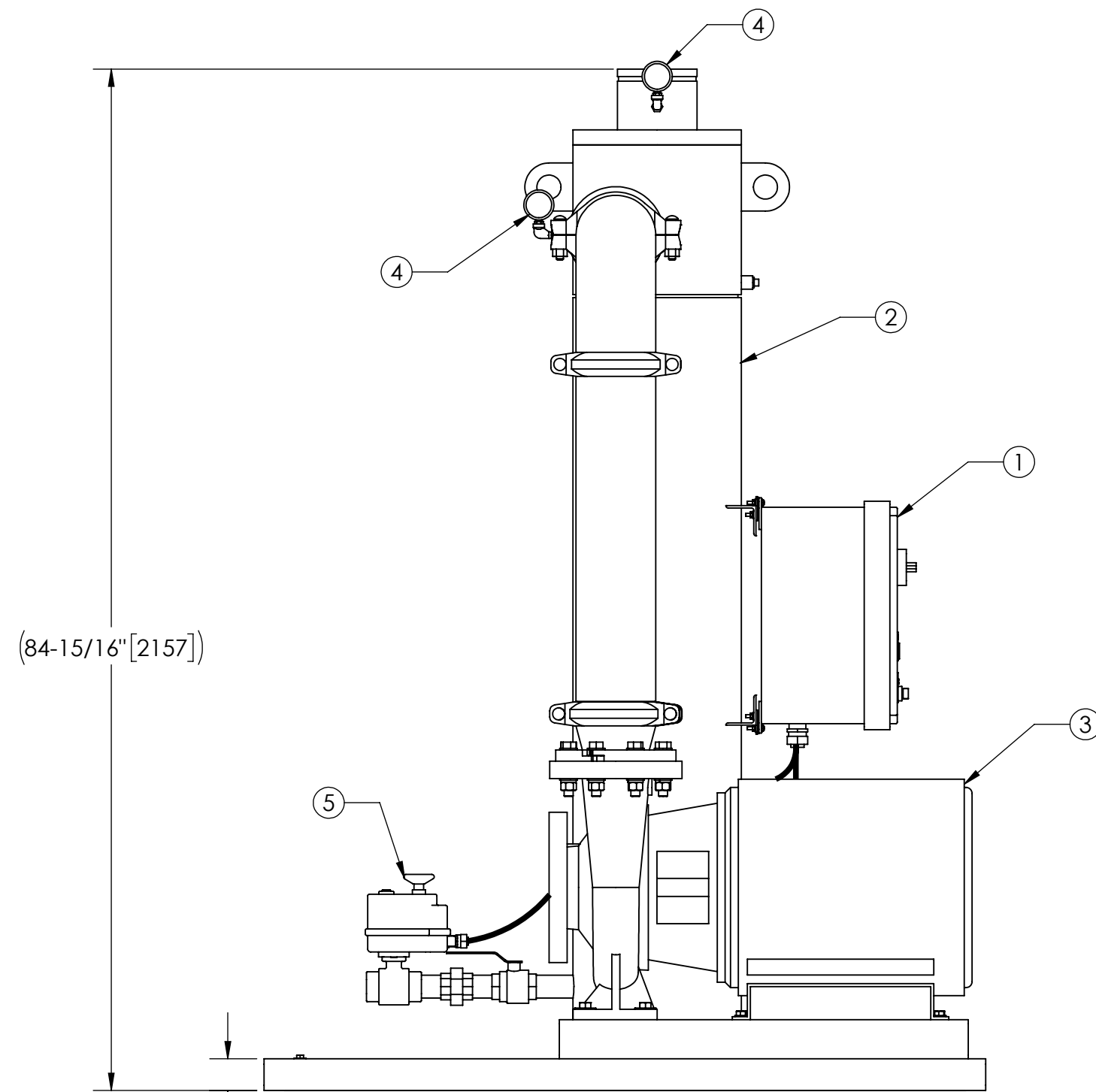

**FRONT VIEW W/O STRAINER**

**SUBMITTAL DRAWING**

This drawing is submitted for spatial consideration only. Do not pre-plumb to these dimensions.

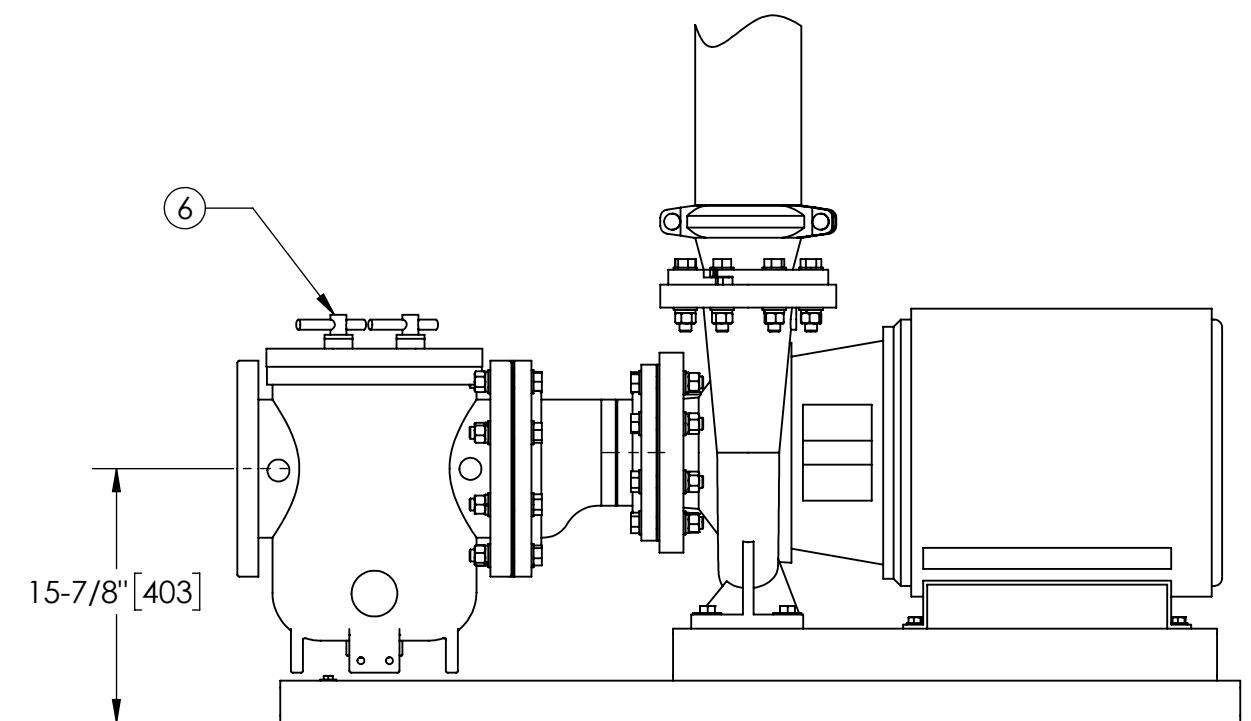

**FRONT VIEW PUMP & STRAINER**

UNLESS OTHERWISE SPECIFIED: DIMENSIONS ARE IN: INCHES (mm) TOLERANCES ARE: FRACTIONS DECIMALS ANGLES ± 1" .XX ± .01 ± 1/4" .XXX ± .005 .XXXX ± .0005		ENGINEERED FOR: <b>STANDARD</b>			
DO NOT SCALE DRAWING	APPROVALS	DATE	TITLE		
MATERIAL PER LAKOS SPEC	DRAWN ADJ	1/5/05	TCI-1100-ABV TC SYSTEM		
FINISH AS ASSEMBLED	ENGR DLW	8/29/07	SWEEPER HTH-0500 3/60/460V		
	REVIEW -	-	SIZE C	MODEL NO.	DWG NO. 123775
	WORK ORDER	QTY.	SCALE 1:12	EST. WT. 2139 lb	SHEET 1 OF 1

DWG. NO. 123775 SHEET 1 REV. E