



## **Installation and Operators Manual**

**Model: eJPX Industrial Separators**



**FRESNO, CALIFORNIA, USA**

# Table of Contents

Principle of Operation .....	3
Flow vs Pressure Drop Chart .....	4
eJPX Separator Model and Flow Chart .....	4
Installation Instructions .....	5
Recommended Inlet & Outlet Piping .....	6
Purging .....	7
Maintenance Recommendations .....	8
Trouble-Shooting Recommendations .....	9
Separator Manifold .....	11
Spare Parts List .....	12

**Please read the entire manual carefully prior to installing, operating or servicing this product. Failure to comply with these instructions may cause personal injury and/or property damage, and may void the warranty of the unit. Always retain this manual f manual can be downloaded at <http://www.lakos.com>.**

**Repairing this equipment while under warranty without prior permission of LAKOS. or the direction of an approved LAKOS service location may void warranty.**

**The shipping contain  
Please check the unit thoroughly upon receipt and note any damage on the delivery receipt. If damage is found, you must then file a claim promptly with the freight carrier.**

## Principle of Operation

LAKOS eJPX Industrial Separators are designed specifically to remove solids from liquids. Each model is engineered to be used within a prescribed flow range for maximum performance and solids removal. Flow rates above and below the recommended range may affect such performance.

Upon tangential entry (Step 1), the liquids/solids are drawn through internal tangential slots (Step 2) and accelerated into the separation chamber where solids heavier than the carrying liquid are centrifugally separated (Step 3) and allowed to accumulate in the unit's collection chamber (Step 6) for eventual purging (Step 8). The liquid (free of separable and settleable solids) is then drawn to the vortex (Step 5) and up through the separator's outlet (Step 7).

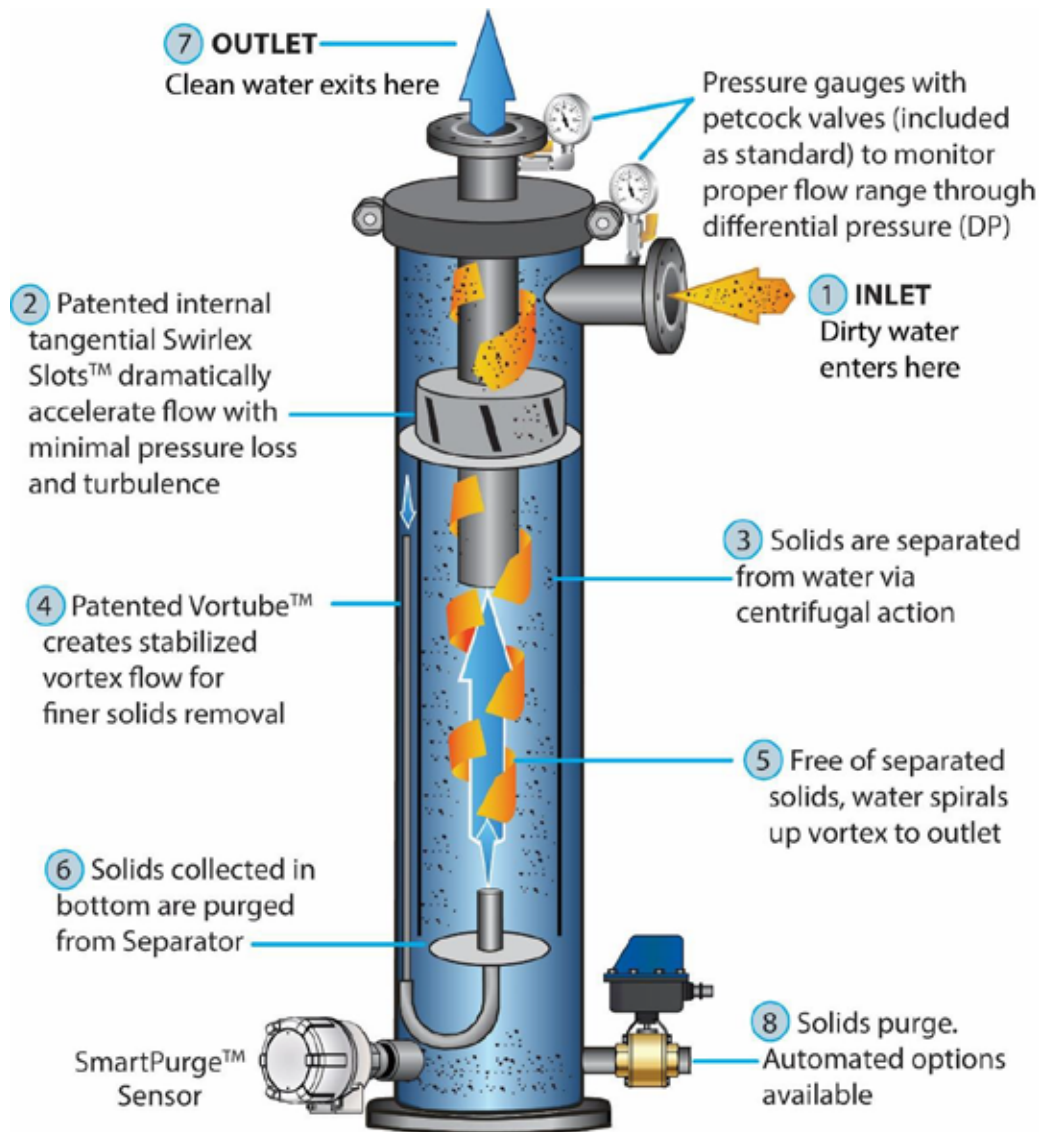

# Flow vs Pressure Drop Chart

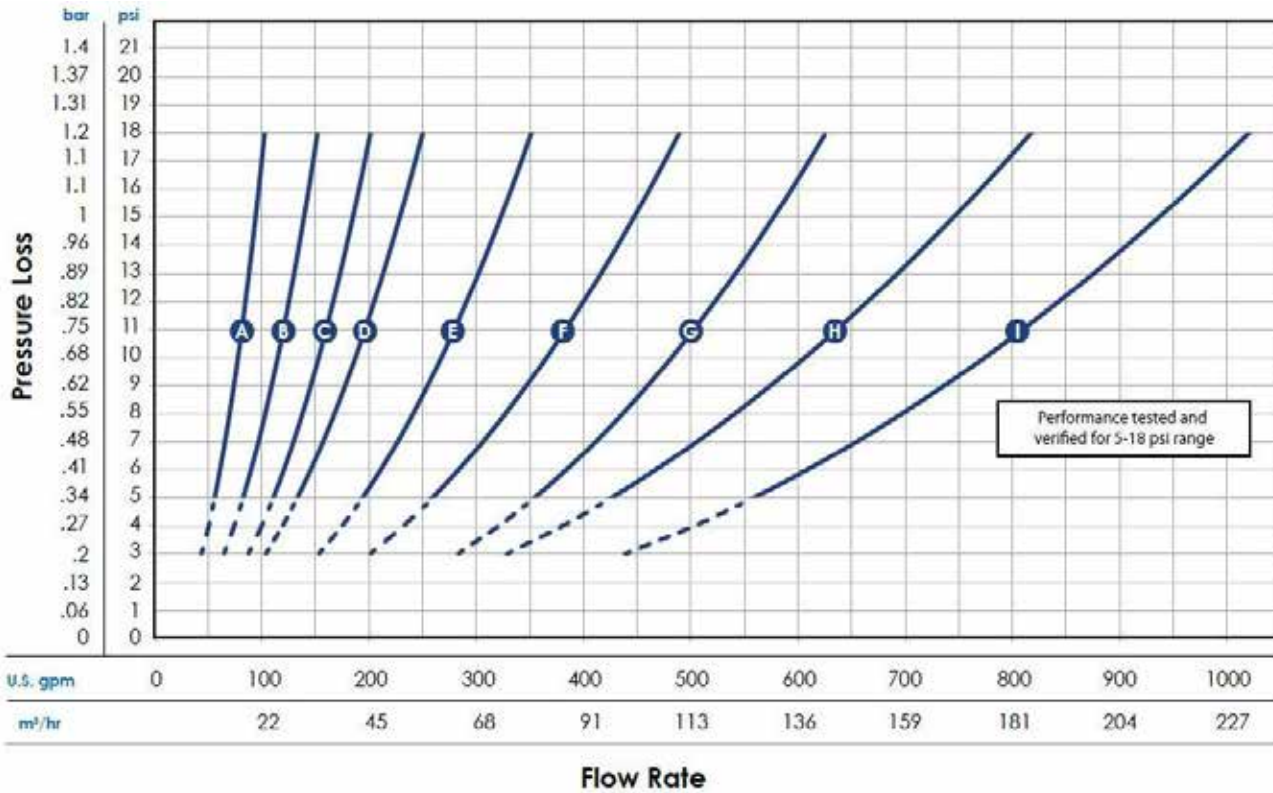

- A eJPX-0055-V
- B eJPX-0080-V
- C eJPX-0110-V
- D eJPX-0135-V
- E eJPX-0195-L/V
- F eJPX-0250-L/V
- G eJPX-0350-L/V
- H eJPX-0425-L/V
- I eJPX-0560-L/V

# eJPX Separator Model and Flow Chart

eJPX Model	Flow Range		Inlet/Outlet	Purge Size NPT	Solids Collection Capacity		Dry Weight		Weight w/ Water	
	US gpm	m³/hr			US gal	liters	lbs	kg	lbs	kg
eJPX-0055	55-100	12-22	1-1/2"	3/4"	0.6	2.4	187	85	258	117
eJPX-0080	80-150	18-34	2"	3/4"	0.6	2.4	228	103	315	143
eJPX-0110	110-200	25-45	2-1/2"	1-1/2"	1.1	4.3	345	156	496	225
eJPX-0135	135-250	30-56	3"	1-1/2"	1.1	4.3	380	172	554	251
eJPX-0195-V	195-350	44-79	4"	1-1/2"	1.7	6.6	535	243	814	369
eJPX-0195-L							583	264	862	391
eJPX-0250-V	250-490	56-111	4"	1-1/2"	1.9	7.1	544	247	847	384
eJPX-0250-L							592	269	895	406
eJPX-0350-V	350-650	79-147	4"	1-1/2"	4.1	15.7	839	381	1444	655
eJPX-0350-L							860	390	1465	665
eJPX-0425-V	425-820	96-186	6"	1-1/2"	5.8	22.1	1093	496	1976	896
eJPX-0425-L							1107	502	1990	903
eJPX-0560-V	560-1030	127-233	6"	1-1/2"	7.6	28.9	1376	624	2568	1165
eJPX-0560-L							1344	610	2536	1150

## *Installation Instructions*

1. LAKOS Separators are shipped on skids or in wooden crates. Support legs (22 ½° low profiles only) are detached. Lifting Lugs, located on the unit's side, are provided for hoisting as necessary.
2. A suitable foundation is necessary to accommodate the LAKOS Separator's weight including liquid. Anchor bolts are recommended in the base of the legs (low profile) or skirt (vertical profile).
3. Prior to installation, inspect the inlet/outlet/purge connections for foreign objects incurred during shipping/storage.
4. It is recommended that the inlet/outlet pipe connections to the LAKOS Separator should be a straight run of at least five pipe diameters to minimize turbulence and enhance performance. It is best to try and keep pipe runs as straight as possible and minimize the number of elbows in the piping. To minimize pipe strain to the separator, suction and discharge pipes should be supported independently.
5. Proper purge hardware and/or solids-handling equipment is required to flush separated solids from the separator.
6. All LAKOS Separators operate within a prescribed flow range (Pipe size is not a factor in model selection). Use appropriate hardware to match the inlet/outlet size. Flange gasket and bolting is not included with the separator. The threads of the pipe fittings screwed into the pump must be sealed with pipe sealants, sealant tape, R.T.V. or other sealing materials approved for pipe threads.
7. Inlet pressure to the LAKOS Separator must be at least equal to or greater than the anticipated pressure loss through the separator plus whatever downstream pressure is required. See page 4 for "Flow vs. Pressure Loss" chart.
8. Pressure gauges are required at both the inlet and outlet of the separator in order to monitor pressure loss and proper flow. If separator operates with an open discharge, a valve should be installed to create a back pressure of at least 5 psi (0.3 bar). Pressure gauge kits are included with all standard LAKOS eJPX Separators.
9. Winterizing is important if the LAKOS Separator is to remain idle in freezing temperatures. Drain all liquid inside the separator to avoid damage due to the expansion of water as it freezes into ice. Heat tracing and insulation can be used to keep liquid from freezing in the separator and causing damage.

LAKOS Separators & Systems must be installed downstream of the main System Pump. Do not install on the suction side of the main system pump. Flow must be pushed through the separator and not pulled. Consult LAKOS for questions.

## Recommended Inlet & Outlet Piping

The inlet and outlet piping of a separator are important to controlling vibration of the unit. LAKOS recommends the illustration configuration below be followed on all units unless absolutely necessary.

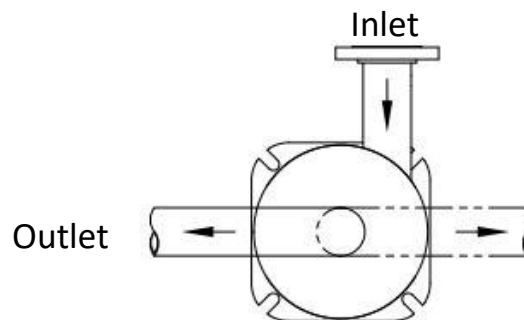
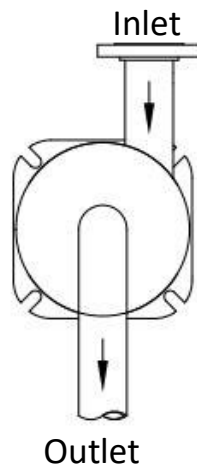
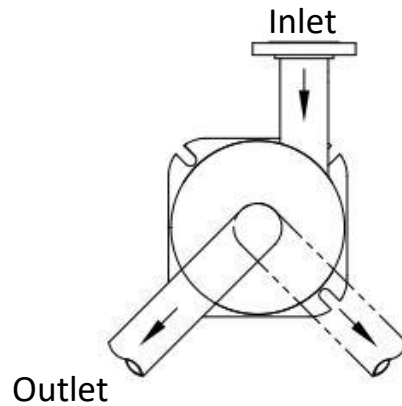

## Purging

1. **Separable and settleable solids collect in the bottom of the separator.** These solids must be regularly removed by opening the purge connection. Pressure inside the separator will flush the solids out.
2. **If the separator is not purged regularly,** the accumulation of separated solids will overflow the separator's collection chamber, adversely affecting performance and causing significant wear damage. Depending upon solids loading, the purge may need to be opened more frequently. See LAKOS literature LS-608 *Purging & Solids Handling*, available for download at <http://www.lakos.com> for guidelines on how to determine purge length and frequency.
3. Solids can be purged to a drain or a filter vessel. Purging must be performed while the LAKOS Separator is in operation.  
Types of purging options:
  - a. **Manual:** A full-port, straight-through valve may be installed on the standard purge opening and actuated manually as necessary to purge separated solids.
  - b. **Semi-Automatic:** The use of LAKOS Separators in a given application typically implies the need for heavy or unusual solids removal. **A LAKOS Solids Recovery Vessel System** is therefore recommended. The BFH-0816 or BFH-0833 allows for continuous purging of the solids collected into a separate collection bag. Once the bag is full with solids, the bag is emptied. Consult your LAKOS representative for details on the solids recovery vessel and accessories.
  - c. **Automatic:** The use of LAKOS Separators in a given application typically implies the need for heavy or unusual solids removal. **A LAKOS Auto-Purge System** is therefore recommended. The electric actuated ball valve assemblies with timer controls allow for the adjustment of the purge frequency and duration based on a job specific application. Other automatic purge options are available. Consult your LAKOS representative for details.
  - d. **SmartPurge:** Used in conjunction with a LAKOS Auto-Purge System, the LAKOS SmartPurge eliminates the need to estimate solids loading or to estimate the appropriate purge frequency. The LAKOS SmartPurge detects the level of accumulated solids via a probe inserted into the separator collection chamber. When the collection chamber has filled with solids, the LAKOS purge valve is automatically signaled to open and purge out the solids. Consult your LAKOS representative for details.
4. eJPX Separators feature standard purge outlets. Prior to start-up, the installation of a manual valve on the purge is recommended so that this outlet may be serviceable at any time for either supplemental purging or as a stand-by.
5. **Important:** All purge hardware should be installed prior to any elbows or turns in the purge piping. **Do not purge uphill.** This can clog piping and hinder effective solids removal.
6. To determine the necessary automatic valve purging frequency, purge often at first and calculate the proper rate with regard to the actual volume of separated solids. Purge duration should be long enough to evacuate the purge chamber of solids. Frequency of purge should not exceed the time it takes to fill the collection chamber. Consult your LAKOS representative for specific recommendations regarding your application.

7. When operating in sub-freezing temperatures, be sure to protect the separator's collection chamber and all purge line piping from freezing. Heat tracing and insulation can also be used to keep liquid from freezing in the separator and causing damage.

## **Maintenance Recommendations**

---

LAKOS recommends periodic inspections of the separator to keep performance at an optimum level.

1. Full Faced Flange Gasket or Victaulic Gaskets should be checked for leaks and replaced as necessary. Gasket should be replaced at disassembly of separator.
2. Hand Hole Clean-out: Hand Hole should be removed to inspect the collection chamber for unwanted build up. Inspection should be conducted annually (or when separator is shut-down for other system service routines). To do so, open the hand-hole clean-out and inspect for solids accumulation or unwanted build-up in the separator's collection chamber. If necessary, remove excessive debris. Inspect gasket and replace if necessary. Check purge programming (if applicable) to be sure it is adequate to remove separated solids; if not, re-set to extend duration and/or frequency of valve actuation.
3. Pressure Gauges: The gauges installed on the inlet and outlet of the LAKOS Separator help monitor proper flow through the separator. They are NOT indicative of solids accumulation and should NOT be used to determine when to purge the separator. Gauges should read a pressure differential loss of 5-18 psi from inlet to outlet and that differential should remain steady with the flow of water through the separator. Fluctuations in gauge readings indicate:
  - a. A change in pump flow – Inspect pump for proper operation and/or downstream piping/equipment for conditions that could create backpressure on the system flow.
  - b. An obstruction in the separator – Internal slots may be clogged by unusual solids. The internal slots are accessible via the removable grooved coupling and top.
  - c. Gauge blockage – Close petcock valve, remove gauge and check for debris clogging the gauge port, which could affect an accurate gauge reading.
4. Separator Slots: Inspection of slots is recommended when separator performance is suspect. Slots should be checked for obstruction and wear.
5. External visual inspection of the separator should be conducted at least once a month. Visual inspection should include observing the inlet and outlet gauges on the separator. This inspection will indicate the pressure drop across the separator. The pressure drop and actual flow rate can be compared to the product brochure to determine if the separator is operating within its expected performance range. Automatic purge or manual purge should be checked for leaks and operation. Purge valve seats or diaphragms should be changed as necessary.



## Troubleshooting Recommendations

1. **Verify Actual Flow Rate:** Use pressure gauges to indicate differential pressure and a flow meter to verify flow rate. Multiple pumps used to increase flow are installed in parallel (into common manifold), while multiple pumps to increase pressure are installed in series (one after another).

Flow meters should be installed prior to the separator. Flow meters installed after the separator will indicate erroneous data.

2. **Plumbing Two Separators:** Do not plumb two separators from two independent pumps into the same outlet header without installing balancing valves on the discharge of each separator. The balancing valves must be set to achieve a pressure loss across each separator that indicates a flow rate (according to that model's published flow chart) equal to the flow rate anticipated through the pump that feeds each separator.
3. **Verify Actual Inlet Pressure:** Actual inlet pressure must be at least equal to or greater than the anticipated pressure loss through the separator plus whatever downstream pressure is required. A minimum backpressure of 5 psi (.34 Bar) must be created at the separator discharge. This may be accomplished via process equipment, piping, or a valve. Unrestricted open discharge to a pit, sump, etc., will result in unacceptable performance.

Be sure that no source of vacuum/suction exists in the piping arrangement. If vacuum/suction exist (i.e. downward piping after the separator, pump suction installation, booster pump etc.), put a valve between the separator and the suction source and pressure gauges on either side of the valve. Throttle the flow until the pressure loss across the separator indicates the published flow rate which most closely resembles the anticipated flow rate through the separator.

4. **Vibration:** Check installation piping inlet & outlet configurations (see appropriate product sheets for model of separator installed). Mild vibration is possible in some installations and should be considered normal. Excessive vibration is typically due to entrained air (use air vents), improper piping (follow the installation instructions) or system vibration (amplified at the separator).

Units should be secured properly to the floor or wall. If the separator is hung, stabilizers may need to be added. The foundation must be sturdy enough to support the weight of the product with water. Expected wet weight is available from the eJPX product literature, available at [www.lakos.com](http://www.lakos.com). (LS-970)

The use of expansion joints is advisable with all separator installations, especially when piping arrangements cannot comply with the configurations suggested by LAKOS product literature.

5. **Purging:** Purge line piping should be as straight as possible to desired disposal destination. Avoid uphill piping, multiple elbows and low points where solids may accumulate and block the piping. Unless advised otherwise, do not reduce the piping size from that of the separator's purge outlet size; restrictions can cause blockage and prevent proper purging of separated solids.

Purge duration should be long enough to not only evacuate solids from the separator, but also to push the solids through the entire length of purge line piping to desired disposal. Typically, we recommend that you program automatic valves, especially motorized ball valves, to purge for no less than 20-25 seconds. This provides time for the valve to remain fully open long enough to flush a separator's collection chamber. Consult LAKOS for unusual circumstances.

**Important:** Note that the collection chamber capacity of each separator (see page 4) should typically not be exceeded by more than 1/3-full (or less). The solids must include sufficient fluid to navigate the purge valve and purge line piping, depending on the solids' capacity to compact and the time frame it takes to accumulate in the separator. Generally, solids should not be allowed to accumulate in the separator's collection chamber for long periods of time. Purging at least daily is recommended when the separator is in operation, more often if the solids tend to compact tightly/easily.

Continuous purging should not exceed 10% of the inlet flow. The use of a valve to bleed solids from a separator must be monitored to be sure that the reduced orifice does not become clogged with solids.

Oversizing the purge line piping may allow solids to settle in the piping; be aware that velocity is needed to flush solids through the purge line piping.

Estimated water & solids volume through a ¾ inch purge outlet is estimated at 10-45 gallons, and a 1 ½ inch purge outlet is estimated at 35-150 gallons. That's a combination of both solids and liquid. The variable takes into account the separator size, flow rate and system pressure. Allow adequate drainage or retention capacity for this volume per purge cycle.

6. **Manifolding Separators:** Two or three stage separators in parallel (for higher flow rates, see page 11) must be purged separately...do not join purges together.
7. **Additional Installation Piping for Separator Accessibility:** eJPX Separators include a removable upper chamber. These separators should be installed with a spool in order to facilitate the removal of the upper chamber.
8. **Flanges/Couplings:** All flanges and/or grooved couplings should have the appropriate gasket/seal in order to ensure a leak-free installation. All hand-hole clean-out ports and other internal access devices should also be properly re-sealed after use.
9. **Air Relief Ports:** The appropriate air relief ports should be used at start-up to expel air from the separator.

If the separator will be drained periodically or exposed to entrained air or gases from the piping system, air vents should be permanently installed.

10. **Down Stream Filtration:** The use of finer filtration (polishing) downstream from the separator is a common application. Be aware, however, that the barrier filter causes an increasing pressure loss (as it accumulates more solids), which may cause the flow rate of the system to be reduced...sometimes below the recommended flow rate of the separator. This situation will

often reveal itself when typical separable solids begin to show up regularly on the downstream barrier filter (leading the customer to possibly believe that the separator does not work). Always check for variations in the flow rate when downstream conditions change.

## Separator Manifold

When water system flow rates exceed that of any single LAKOS eJPX Separator, manifolding two or more separators together can help achieve large flow requirements. Manifolding multiple units keeps units smaller, easier to install and provides for future flow rate changes.

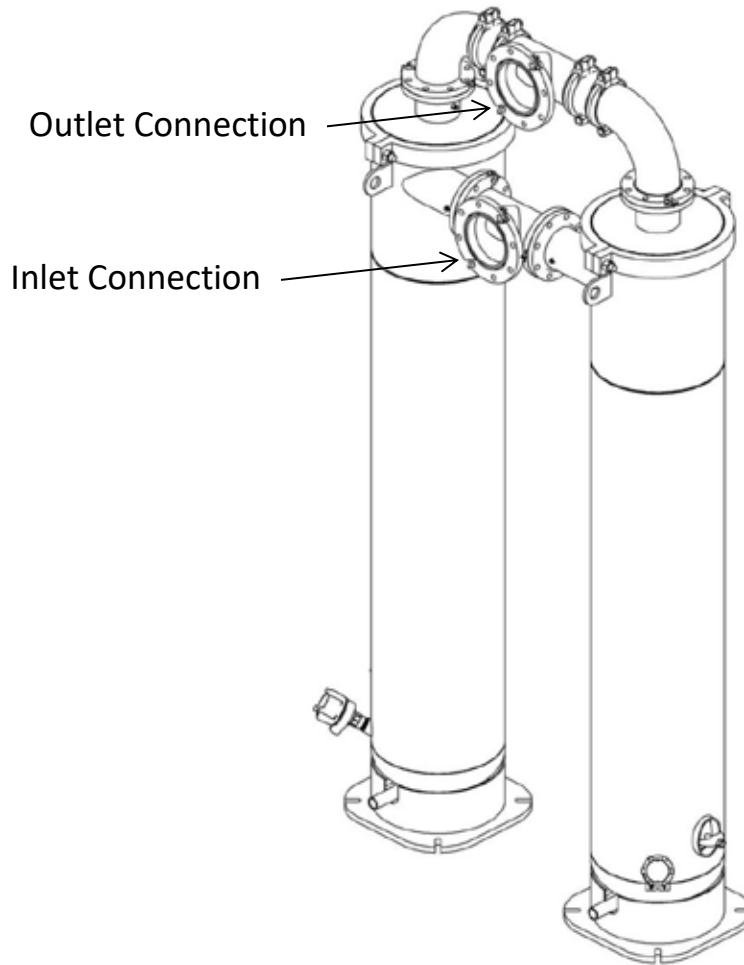

## Spare Parts List

### eJPX-0055

PART#	ITEM	DESCRIPTION	DETAILS	MATERIALS
120761	SHEET	RUBBER ¼" THK	2-3/4"OD x 1-15/16" ID	EPDM
106147	GASKET	COUPLING	8 TYPE E GROOVE	EPDM
118512	GKT	KIT	GAUGES 0- 160PSI	ASSEMBLY
119340	GASKET	HANDHOLE	3" X 4"	EPDM

### eJPX-0080

PART#	ITEM	DESCRIPTION	DETAILS	MATERIALS
120761	SHEET	RUBBER ¼" THK	3"OD x 2-7/16" ID	EPDM
106147	GASKET	COUPLING	8 TYPE E GROOVE	EPDM
118512	GKT	KIT	GAUGES 0- 160PSI	ASSEMBLY
119340	GASKET	HANDHOLE	3" X 4"	EPDM

### eJPX-0110

PART#	ITEM	DESCRIPTION	DETAILS	MATERIALS
120761	SHEET	RUBBER ¼" THK	3-7/8"OD x 2-15/16" ID	EPDM
106149	GASKET	COUPLING	10 TYPE E GROOVE	EPDM
118512	GKT	KIT	GAUGES 0- 160PSI	ASSEMBLY
119340	GASKET	HANDHOLE	3" X 4"	EPDM

**eJPX-0135**

PART#	ITEM	DESCRIPTION	DETAILS	MATERIALS
120761	SHEET	RUBBER ¼" THK	3-7/8"OD x 3-1/16" ID	EPDM
106149	GASKET	COUPLING	10 TYPE E GROOVE	EPDM
118512	GKT	KIT	GAUGES 0- 160PSI	ASSEMBLY
119340	GASKET	HANDHOLE	3" X 4"	EPDM

**eJPX-0195**

PART#	ITEM	DESCRIPTION	DETAILS	MATERIALS
120761	SHEET	RUBBER ¼" THK	4-1/2"OD x 3-9/16" ID	EPDM
106150	GASKET	COUPLING	12 TYPE E GROOVE	EPDM
118512	GKT	KIT	GAUGES 0- 160PSI	ASSEMBLY
127244	GASKET	HANDHOLE	4" X 6"	EPDM

**eJPX-0250**

PART#	ITEM	DESCRIPTION	DETAILS	MATERIALS
120761	SHEET	RUBBER ¼" THK	5"OD x 4-1/16" ID	EPDM
106150	GASKET	COUPLING	12 TYPE E GROOVE	EPDM
118512	GKT	KIT	GAUGES 0- 160PSI	ASSEMBLY
127244	GASKET	HANDHOLE	4" X 6"	EPDM

**eJPX-0350**

PART#	ITEM	DESCRIPTION	DETAILS	MATERIALS
120761	SHEET	RUBBER ¼" THK	5-1/2"OD x 4-9/16" ID	EPDM
117152	GASKET	COUPLING	16 TYPE E GROOVE	EPDM
118512	GKT	KIT	GAUGES 0- 160PSI	ASSEMBLY
127244	GASKET	HANDHOLE	4" X 6"	EPDM

**eJPX-0425**

PART#	ITEM	DESCRIPTION	DETAILS	MATERIALS
120761	SHEET	RUBBER ¼" THK	6"OD x 5-1/16" ID	EPDM
119036	GASKET	COUPLING	18 TYPE E GROOVE	EPDM
118512	GKT	KIT	GAUGES 0- 160PSI	ASSEMBLY
127244	GASKET	HANDHOLE	4" X 6"	EPDM

**eJPX-0560**

PART#	ITEM	DESCRIPTION	DETAILS	MATERIALS
120761	SHEET	RUBBER ¼" THK	6-5/8"OD x 5-5/8" ID	EPDM
119488	GASKET	COUPLING	20 TYPE E GROOVE	EPDM
118512	GKT	KIT	GAUGES 0- 160PSI	ASSEMBLY
127244	GASKET	HANDHOLE	4" X 6"	EPDM

# Notes

---

Separator Model: \_\_\_\_\_

Sales Order #: \_\_\_\_\_

Purchase Date: \_\_\_\_\_

Distributor: \_\_\_\_\_

System Flow: \_\_\_\_\_

Separator Inlet Pressure: \_\_\_\_\_

Separator Outlet Pressure: \_\_\_\_\_

---

---

---

---

---

---

LAKOS  
1365 N. Clovis Ave  
Fresno, California 93727  
Ph: (559) 255-1601  
[www.lakos.com](http://www.lakos.com)