



LAKOS[®]
FILTRATION SOLUTIONS

Installation and Operators Manual

Model: eHTX Series High Efficiency Separators



FRESNO, CALIFORNIA, USA

TABLE OF CONTENTS

Page 2.....	Table of Contents
Page 3.....	Principle of Operation
Page 4.....	Pressure Drop vs. Flow
Page 4.....	Separator Models
Page 5.....	Installation Instructions
Page 6.....	Inlet/Outlet Piping
Page 7-8.....	Maintenance
Page 9-11.....	Trouble Shooting
Page 12.....	Separator Manifolding
Page 13-14.....	Spare Parts
Page 15.....	Notes

Principle of Operation “How it Works”

LAKOS eHTX Separators are designed specifically to remove solids from liquids. Each model is calculated for use within a prescribed flow range for maximum performance and solids removal. Flow rates above and below the recommended range may affect such performance.

Upon tangential entry, the liquid/solids are drawn through internal tangential slots and accelerated into the separation chamber where solids heavier than the carrying liquid are centrifugally separated and allowed to accumulate in the unit’s collection chamber for eventual purging. The liquid (free of separable solids) is then drawn to the vortex and up through the separator’s outlet.

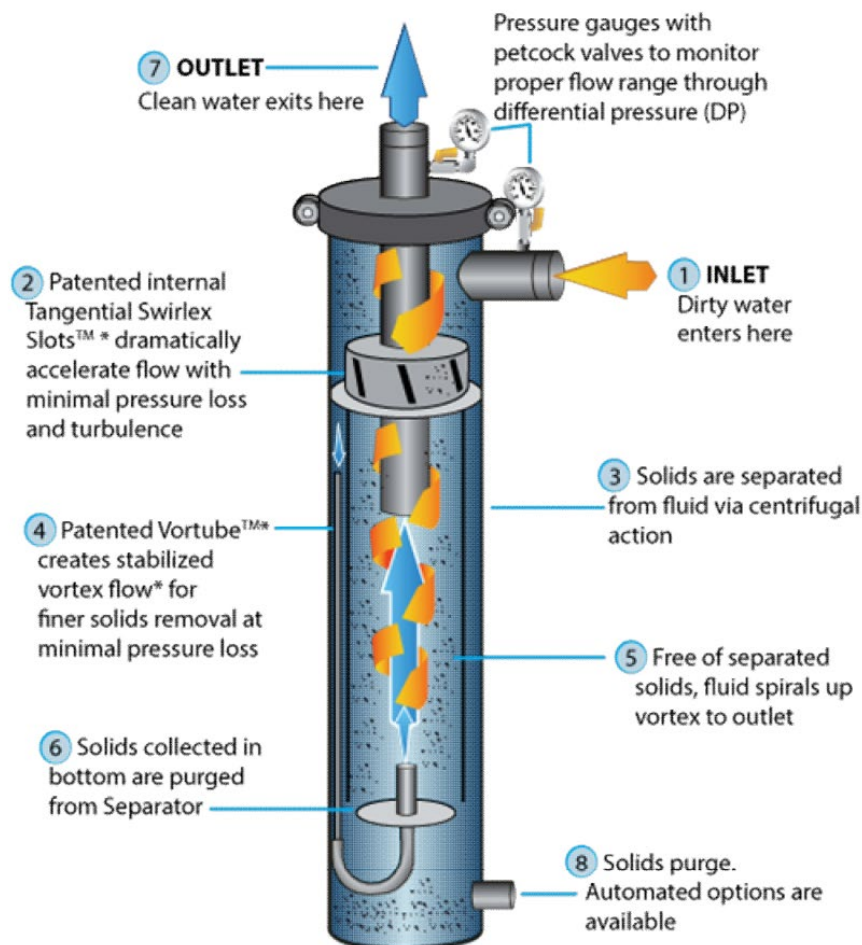

Flow vs. Pressure Drop Chart

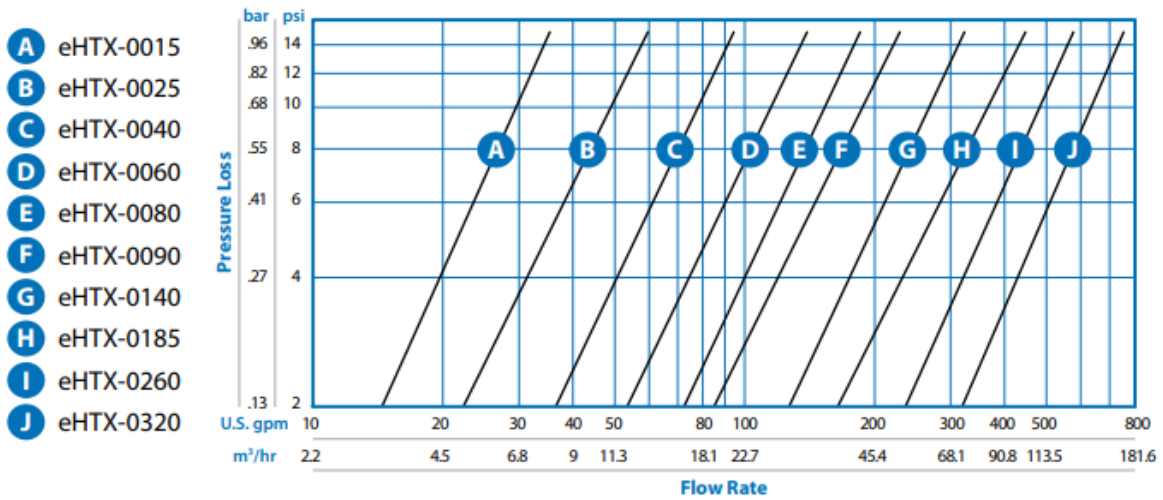

eHTX Separator Model and Flow Chart

Model	Flow Range		Inlet/Outlet Grooved Size	Collection Chamber Capacity		Weight Empty		Weight with Water	
	US gpm	m³/hr		gal	liters	lbs	kg	lbs	kg
eHTX-0040-V	40-95	21-Sep	1-1/2 inch	0.6	2.3	184	83	257	117
eHTX-0060-V	60-140	13-31	2 inch	0.6	2.3	221	100	305	138
eHTX-0080-V	80-185	18-42	2-1/2 inch	1.2	4.5	298	135	456	207
eHTX-0090-V	90-230	20-52	3 inch	1.2	4.5	328	149	508	230
eHTX-0140-V	140-325	32-74	4 inch	1.7	6.4	486	220	772	350
eHTX-0185-V	185-450	42-102	4 inch	1.7	6.4	498	226	807	336
eHTX-0260-V	260-585	59-133	4 inch	3.2	12.1	768	349	1362	609
eHTX-0320-V	320-770	73-172	6 inch	3.4	12.8	979	444	1789	813

Installation Instructions

1. LAKOS Separators are shipped on steel skids or in wooden crates. Support legs (22 ½° low profiles only) are detached. Lifting lugs, located on the unit's side and/or flanges, are provided for hoisting as necessary.
2. A suitable foundation is necessary to accommodate the LAKOS Separator's weight *including liquid*. Anchor bolts are recommended in the base of the legs (low profile) or skirt (vertical profile).
3. Prior to installation, inspect the inlet/outlet/purge connections for foreign objects inserted during shipping/storage.
4. It is recommended that the inlet/outlet pipe connections to the LAKOS Separator should be a straight run of at least five pipe diameters (if possible) to minimize turbulence and enhance performance. It is best to keep pipe runs as straight as possible and minimize the number of elbows in the piping.
5. Proper purge hardware and/or solids-handling equipment is required to flush separated solids from the separator.
6. All LAKOS Separators operate within a prescribed flow range (pipe size is not a factor in model selection). Use appropriate hardware to match the inlet/outlet size. Grooved couplings are not included with the separator. Optional flanged connections are available upon request.
7. Inlet pressure to the LAKOS Separator must be at least equal to or greater than the anticipated pressure loss through the separator plus 15 psi (1 bar) plus whatever downstream pressure is required. See page 4 for "Flow vs. Pressure Loss" chart.
8. Pressure gauges are required at both the inlet and outlet of the separator in order to monitor pressure loss and proper flow. If the separator operates with an open discharge, a valve should be installed to create a back pressure of at least 5 psi (0.3 bar).
9. Winterizing is important if the LAKOS Separator is to remain idle in freezing temperatures. Drain liquid as necessary to avoid expansion of water to ice and related damage. Heat tracing and insulation can also be used to keep liquid from freezing in the separator and causing damage.

Recommended Inlet & Outlet Piping

The inlet and outlet piping of a separator are important for controlling vibration of the unit. The vibration is more prevalent in units larger than 6", however, LAKOS recommends the illustration configuration below be followed on all units. The factory should be consulted on units larger than 6" if configurations cannot be followed.

Recommended direction of inlet/outlet piping to control vibration

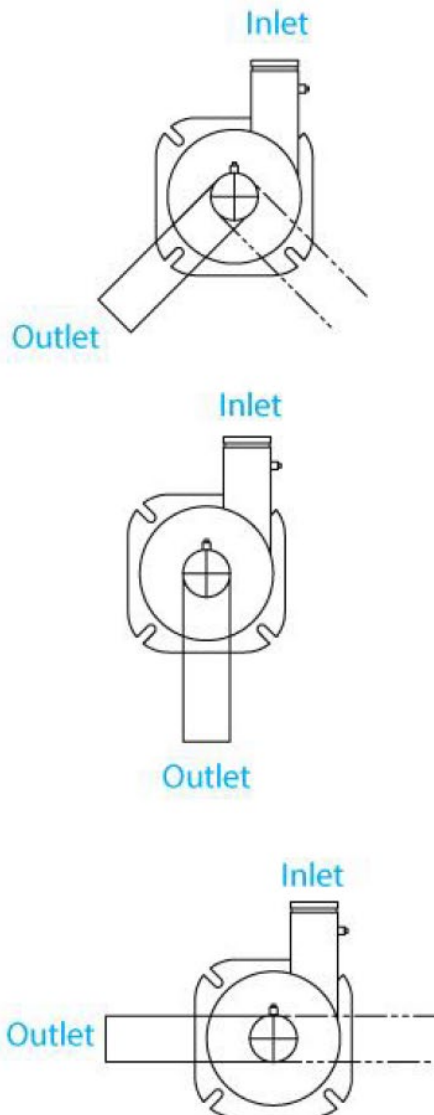

Maintenance/Purging

1. **LAKOS Separators must be purged regularly.** The over-accumulation of separated solids will overflow the separator's collection chamber, substantially affecting performance and causing undue wear.
2. Several purging options are available and all may be performed while the LAKOS Separator is in full operation.
 - a. **Manual:** A full-port, straight-through valve may be installed on the standard purge opening and actuated manually as necessary to purge separated solids.
 - b. **Semi-Automatic:** The use of LAKOS Separators in a given application typically implies the need for heavy or unusual solids removal. **A LAKOS Solids Recovery Vessel System (SRV)** is therefore recommended. The SRV-816 or SRV-833 allows for continuous purging of the solids collected into a separate collection bag. Once the bag is full with solids, the bag is emptied. The bag (10 micron recommended) can be cleaned and reused or simply replaced. Consult your LAKOS representative for details on the solids recovery vessel and accessories.
 - c. **Automatic:** The use of LAKOS Separators in a given application typically implies the need for heavy or unusual solids removal. **A LAKOS Auto-Purge System** is therefore recommended. The Automated Ball Valve (ABV) and Electric Fail-Safe Valves (EFS) are electric actuated ball valve assemblies with timer controls to allow for the adjustment of the purge frequency and duration based on a job specific application. The EFS is a battery backup style failsafe actuator that will ensure closure of the valve even if there is a loss of power to the controller. Consult your LAKOS representative for details.
3. eHTX Separators feature standard purge outlets. Prior to start-up, the installation of a manual valve on the purge is recommended so that this outlet may be serviceable at any time for either supplemental purging or as a stand-by, should the primary purge line ever require servicing.
4. **Important:** All purge hardware should be installed prior to any elbows or turns in the purge piping. Avoid "uphill" purging, which can clog piping and hinder effective solids evacuation.
5. To determine the necessary ABV or EFS purging frequency, purge often at first and calculate the proper rate with regard to the actual volume of separated solids. Purge duration should be long enough to evacuate the purge chamber of solids. Frequency of purge should not exceed the time it takes to over fill the collection chamber. Consult your LAKOS representative for specific recommendations regarding your application.
6. When operating in sub-freezing temperatures, be sure to protect the separator's collection chamber and all purge line piping from freezing. Heat tracing and insulation can also be used to keep liquid from freezing in the separator and causing damage.

Maintenance Recommendations

LAKOS recommends periodic inspections of the separator to keep performance at an optimum level.

1. Flange gaskets or victaulic gaskets should be checked for leaks and replaced as necessary. Gaskets should be replaced at disassembly of separator.
2. Hand hole clean-out: Hand hole should be removed to inspect the collection chamber for unwanted build up. Inspection should be conducted annually (or when separator is shut-down for other system service routines), open the hand hole clean-out and inspect for solids accumulation or unwanted build-up in the separator's collection chamber. If necessary, remove excessive debris. Inspect gasket and replace if necessary. Check purge programming (if applicable) to be sure it is adequate to remove separated solids; if not, re-set to extend duration and/or frequency of valve actuation.
3. Pressure gauges: The gauges installed on the inlet & outlet of the LAKOS Separator help monitor proper liquid flow through the separator. They are NOT indicative of solids accumulation and should NOT be used to determine when to purge the separator. Gauges should read a pressure differential loss of 2-15 psi from inlet to outlet and that differential should remain steady with the flow of water through the separator. Fluctuations in gauge readings indicate:
 - a. A change in pump flow – Inspect pump for proper operation and/or downstream piping/equipment for conditions that could create backpressure on the system flow.
 - b. An obstruction in the separator – Internal slots may be clogged by unusual solids. Use a video scope to examine & remove blockages from internal slotting. Consult LAKOS if necessary.
 - c. Gauge blockage – Close petcock valve, remove gauge and check for debris clogging the gauge port, which could affect an accurate gauge reading.
4. Separator slots should be inspected during facility pipe inspection. Inspection of slots is recommended when separator performance is suspect. Slots should be checked for obstruction and wear.
5. Visual inspection of the separator should be conducted at least once a month. Visual inspection should also include observing the inlet and outlet gauges on the separator. This inspection will indicate the pressure drop across the separator. The pressure drop and actual flow rate can be compared to the product brochure to determine if the separator is operating within its expected performance range. Automatic purge or manual purge should be checked for leaks and operation. Purge valve seats or diaphragms should be changed as necessary.

Trouble-Shooting Guidelines for Separator Installations

1. **Verify Actual Flow Rate:** Use pressure gauges to indicate differential pressure and flow meter to verify flow rate. (Multiple pumps used to increase flow are installed in parallel (into common manifold); multiple pumps to increase pressure are installed in series (one after another).

Flow meters should be installed prior to the separator. Flow meters installed after the separator will indicate erroneous data.

2. **Plumbing Two Separators:** Do not plumb two separators from two independent pumps into the same outlet header without installing balancing valves on the discharge of each separator. The balancing valves must be set to achieve a pressure loss across each separator that indicates a flow rate (according to that model's published flow chart) equal to the flow rate anticipated through the pump that feeds each separator.
3. **Verify Actual Inlet Pressure:** Actual inlet pressure must be at least 15 psi (1.03 bar). A minimum backpressure of 5 psi (.34 bar) must be created at the separator discharge. This may be accomplished via process equipment, piping, or a valve. Unrestricted open discharge to a pit, sump, etc., will result in unacceptable performance.

Be sure that no source of vacuum/suction exists in the piping arrangement. If vacuum/suction exists (i.e. downward piping after the separator, pump suction installation, booster pump etc.), put a valve between the separator and the suction source and pressure gauges on either side of the valve. Throttle the flow until the pressure loss across the separator indicates the published flow rate which most closely resembles the anticipated flow rate through the separator.

4. **Vibration:** Check installation piping inlet & outlet configurations (see appropriate product sheets for model of separator installed). Mild vibration is possible in some installations and should be considered normal. Excessive vibration is typically due to entrained air (use air vents), improper piping (follow the installation instructions) or system vibration (amplified at the separator).

Units should be secured properly to the floor or wall. If separator is hung, stabilizers may need to be added. The foundation must be sturdy enough to support the weight of the product (expected wet weight can be obtained from the product literature).

The use of expansion joints is advisable with all separator installations. It is particularly recommended that these devices be employed when piping arrangements cannot comply with the configurations suggested by LAKOS product literature.

5. **Vertical Units:** Be aware that solids may accumulate within the separator for a period of time until the solids reach the level of the purge outlet. The purge outlet is not flush with the bottom of the solids collection chamber.

6. **Purging:** Purge line piping should be as straight as possible to desired disposal destination. Avoid uphill piping, multiple elbows and low points where solids may accumulate and block the piping. Unless advised otherwise, do not reduce the piping size from that of the separator's purge outlet size; restrictions can cause blockage and prevent proper purging of separated solids.

Purge duration should be long enough to not only evacuate solids from the separator, but also to push the solids through the entire length of purge line piping to desired disposal. Typically, we recommend that you program automatic valves, especially motorized ball valves, to purge for no less than 20-25 seconds. This provides time for the valve to remain fully open long enough to flush a separator's collection chamber. Consult LAKOS for unusual circumstances.

Important: Note that the collection chamber capacity of each separator (see page 4) should typically not be exceeded. The solids must include sufficient fluid to navigate the purge valve & purge line piping. It depends on the solids' capacity to compact and the time frame it takes to accumulate in the separator. Generally, solids should not be allowed to accumulate in the separator's collection chamber for long periods of time; purging at least daily is recommended when the separator is in operation, more often if the solids tend to compact tightly/easily.

Continuous purging should not exceed 10% of the inlet flow. The use of a valve to bleed solids from a separator must be monitored to be sure that the reduced orifice does not become clogged with solids.

Oversizing the purge line piping may allow solids to settle in the piping; be aware that velocity is needed to flush solids through the purge line piping.

Estimated water & solids volume through a $\frac{3}{4}$ inch purge outlet is estimated at 10-45 gallons, and a 1 $\frac{1}{2}$ inch purge outlet is estimated at 35-150 gallons. That's a combination of both solids and liquid. The variable takes into account the separator size, flow rate and system pressure. Allow adequate drainage or retention capacity for this volume per purge cycle.

7. **Manifolding Separators:** Two or three separators in parallel (for higher flow rates, see page 12) must be purged separately...do not join purges together.

8. **Additional Installation Piping for Separator Accessibility:** Separators which feature a removable upper chamber should be installed with a spool in order to facilitate the removal of the upper chamber.
9. **Flanges/Couplings:** All flanges and/or grooved couplings should have the appropriate gasket/seal in order to ensure a leak-free installation. All hand hole clean-out ports and other internal access devices should also be properly re-sealed after use.
10. **Air Relief Ports:** The appropriate air relief ports should be used at start-up to expel air from the separator.

If the separator will be drained periodically or exposed to entrained air or gases from the piping system, air vents should be permanently installed.

11. **Down Stream Filtration:** The use of finer filtration (polishing) downstream from the separator is a common application. Be aware, however, that the barrier filter (as it accumulates more solids) causes an increasing pressure loss, which may cause the flow rate of the system to be reduced...sometimes below the recommended flow rate of the separator. This situation will often reveal itself when typical separable solids begin to show up regularly on the downstream barrier filter (leading the customer to possibly believe that the separator does not work). Always check for variations in the flow rate when downstream conditions change.

Separator Manifold

Manifolding in Parallel for High Flow Rates

When water system flow rates exceed that of any single LAKOS Separator, manifolding two or more separators together can help achieve large flow requirements. Manifolding multiple units keeps units smaller, easier to install and provides for future flow rate changes.

*Example: Three eHTX-0185 Separators
increases flow range to 555 - 1350 US
gpm (126 - 307 m³/hr)*

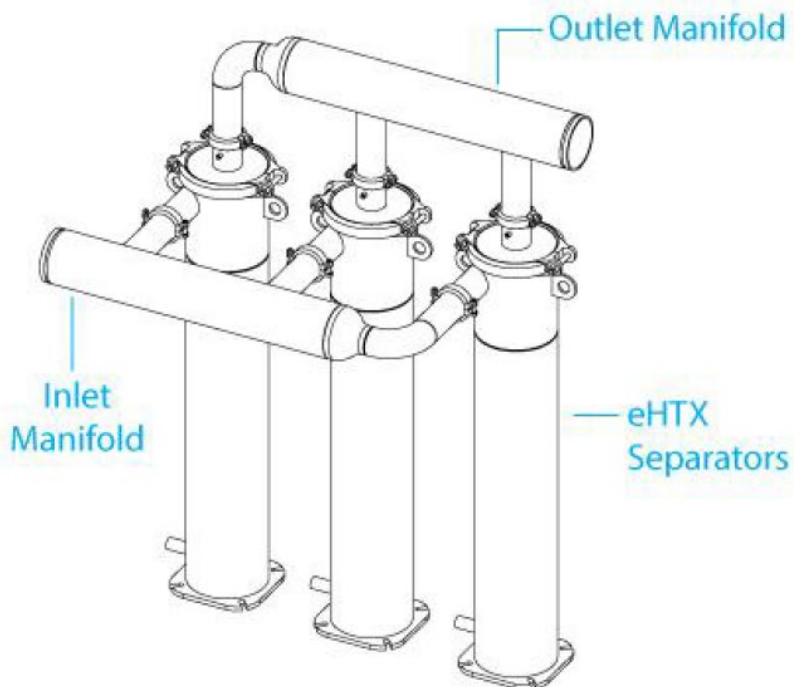

eHTX Spare Parts List

eHTX-0040-V

PART#	DESC	DESCRIPTION TWO	DESCRIPTION THREE	DESCRIPTION FOUR
120761	SHEET	RUBBER 1/4" THK	2-3/4"OD x 1-15/16" ID	EPDM
106147	GASKET	COUPLING	8 TYPE E GROOVE	EPDM
118512	GKT	KIT	GAUGES 0- 160PSI	ASSEMBLY

eHTX-0060-V

PART#	DESC	DESCRIPTION TWO	DESCRIPTION THREE	DESCRIPTION FOUR
120761	SHEET	RUBBER 1/4" THK	3" OD x 2-7/16" ID	EPDM
106147	GASKET	COUPLING	8 TYPE E GROOVE	EPDM
118512	GKT	KIT	GAUGES 0- 160PSI	ASSEMBLY

eHTX-0080-V

PART#	DESC	DESCRIPTION TWO	DESCRIPTION THREE	DESCRIPTION FOUR
120761	SHEET	RUBBER 1/4" THK	3-7/8" OD x 3-1/16" ID	EPDM
106149	GASKET	COUPLING	10 TYPE E GROOVE	EPDM
118512	GKT	KIT	GAUGES 0- 160PSI	ASSEMBLY

eHTX-0090-V

PART#	DESC	DESCRIPTION TWO	DESCRIPTION THREE	DESCRIPTION FOUR
120761	SHEET	RUBBER 1/4" THK	3-7/8" OD x 3-1/16" ID	EPDM
106149	GASKET	COUPLING	10 TYPE E GROOVE	EPDM
118512	GKT	KIT	GAUGES 0-160PSI	ASSEMBLY

eHTX-0140-V

PART#	DESC	DESCRIPTION TWO	DESCRIPTION THREE	DESCRIPTION FOUR
120761	SHEET	RUBBER 1/4" THK	4-1/2" OD x 3-9/16" ID	EPDM
106150	GASKET	COUPLING	12 TYPE E GROOVE	EPDM
118512	GKT	KIT	GAUGES 0-160PSI	ASSEMBLY
106205	GASKET	HAND HOLE	4" x 6"	NEOPRENE

eHTX-0185-V

PART#	DESC	DESCRIPTION TWO	DESCRIPTION THREE	DESCRIPTION FOUR
118504	SHEET	RUBBER 1/4" THK	5" OD x 4-1/16" ID	EPDM
106150	GASKET	COUPLING	12 TYPE E GROOVE	EPDM
118512	GKT	KIT	GAUGES 0- 160PSI	ASSEMBLY
106205	GASKET	HAND HOLE	4" x 6"	NEOPRENE

***e*HTX-0260-V**

PART#	DESC	DESCRIPTION TWO	DESCRIPTION THREE	DESCRIPTION FOUR
120761	SHEET	RUBBER 1/4" THK	5-1/2" OD x 4-1/16" ID	EPDM
117152	GASKET	COUPLING	16 TYPE E GROOVE	EPDM
118512	GKT	KIT	GAUGES 0- 160PSI	ASSEMBLY
106205	GASKET	HAND HOLE	4" x 6"	NEOPRENE

***e*HTX-0320-V**

PART#	DESC	DESCRIPTION TWO	DESCRIPTION THREE	DESCRIPTION FOUR
125053	SHEET	RUBBER 1/8" THK	6" OD x 5-1/16" ID	EPDM
119036	GASKET	COUPLING	18 TYPE E GROOVE	EPDM
118512	GKT	KIT	GAUGES 0- 160PSI	ASSEMBLY
106205	GASKET	HAND HOLE	4" x 6"	NEOPRENE

Notes:

Separator Model: _____

Sales Order #: _____

Purchase Date: _____

Distributor: _____

System Flow: _____ **Separator Delta P:** _____



**1365 North Clovis Avenue
Fresno, CA 93727-2282**

**Fax: 1-559-255-8093
Phone: (559)255-1601
info@lakos.com www.lakos.com**